

The Genetic Basis for Male × Female Interactions Underlying Variation in Reproductive Phenotypes of *Drosophila*

Clement Y. Chow,¹ Mariana F. Wolfner and Andrew G. Clark

Department of Molecular Biology and Genetics, Cornell University, Ithaca, New York 14853-2703

Manuscript received June 10, 2010
Accepted for publication September 20, 2010

ABSTRACT

In *Drosophila*, where females mate multiply, sperm competition contributes strongly to fitness variability among males. Males transfer “Acp” seminal proteins to females during mating, and these proteins influence the outcome of sperm competition. Because Acps function within the female, male proteins can directly interact with female molecules in a manner that affects reproductive fitness. Here we begin to dissect the genetic architecture of male × female interactions underlying reproductive phenotypes important to sperm competition. By utilizing chromosome extraction lines, we demonstrate that the third and X chromosomes each have large effects on fertility phenotypes, female remating rate, and the sperm competition parameter, P1. Strikingly, the third and X chromosomes harbor genetic variation that gives rise to strong male × female interactions that modulate female remating rate and P1. Encoded on these chromosomes are, respectively, sex peptide (SP) and sex peptide receptor (SPR), the only pair of physically interacting male Acp and female receptor known. We identified several intriguing allelic interactions between *SP* and *SPR*. The results of this study begin to elucidate the complex genetic architecture of reproductive and sperm competition phenotypes and have significant implications for the evolution of male and female characters.

IN most organisms, extensive variation in reproductive success exists. The male and female effects of this variation are often strongly nonadditive. In *Drosophila*, where multiple matings occur frequently (HARSHMAN and CLARK 1998; IMHOF *et al.* 1998), one major source of variation in male reproductive success is sperm competition. Sperm competition occurs when sperm from multiple males are present within a female. In the laboratory, sperm competition trials often involve mating a female with two different males in timed succession and measuring the proportion of progeny from each male. The magnitude of among-male variation in sperm competition is enormous, with some males appearing >10 times as successful as other males at competing (FIUMERA *et al.* 2007). To maintain such a high level of fitness variation in a population (HUGHES 1997), there must be high levels of functional polymorphism in genes underlying sperm competition.

Drosophila accessory gland proteins (Acps) are critical components of the seminal fluid, mediating many physiological and behavioral changes in the mated

female. These changes include effects on egg production and egg laying rate, sperm storage patterns, expression of antimicrobial peptides, feeding rate, remating rate, longevity, locomotion, and sleep patterns (reviewed in WOLFNER 2009; see also ISAAC *et al.* 2010). Over 100 Acps have been identified (*e.g.*, see RAVI RAM and WOLFNER 2007a; FINDLAY *et al.* 2008, 2009). Of particular relevance to this study, Acps have been shown to be critical to sperm competitive success (HARSHMAN and PROUT 1994; CHAPMAN *et al.* 2000; WONG *et al.* 2008a; AVILA and WOLFNER 2009), and Acp alleles are associated with sperm competition outcomes (CLARK *et al.* 1995; FIUMERA *et al.* 2005, 2007).

Sperm competition is subject to sexual selection due to the differing reproductive “interests” of the sexes (PARKER 1970). For evolution by sexual selection to occur, population level variation must exist in alleles for Acps and other reproductive proteins influencing success in sperm competition. Indeed, studies have demonstrated that some Acps have high levels of variation (AGUADÉ *et al.* 1992; TSAUR and WU 1997; TSAUR *et al.* 1998; SWANSON *et al.* 2001; SWANSON and VACQUIER 2002; HAERTY *et al.* 2007) that show non-neutral patterns of evolution (CIVETTA and SINGH 1998; SWANSON *et al.* 2001; SWANSON and VACQUIER 2002; BEGUN and LINDFORS 2005; MUELLER *et al.* 2005; WONG *et al.* 2008b; KELLEHER and MARKOW 2009). Extraordinarily high levels of sequence variation have been found in male reproductive proteins across many taxa (SWANSON

Supporting information is available online at <http://www.genetics.org/cgi/content/full/genetics.110.123174/DC1>.

Sequence data from this article have been deposited with the EMBL/GenBank Data Libraries under accession nos. HQ381081–HQ381368.

¹Corresponding author: Department of Molecular Biology and Genetics, Cornell University, 227 Biotechnology Bldg., Ithaca, NY 14853-2703. E-mail: cyc8@cornell.edu

and VACQUIER 2002). It remains a mystery why such important genes controlling reproductive fitness maintain such high levels of variation. One possible mechanism for maintaining polymorphism is antagonistic pleiotropy. This phenomenon results in a trade-off between effects of alleles where, as second males, a particular allele results in more offspring sired, but as a first male, the same allele results in reduced ability to prevent remating. This trade-off may maintain genetic variation that benefits one sperm competition trait at the expense of another. Antagonistic pleiotropy has been demonstrated for several Acp genes (FIUMERA *et al.* 2007). Furthermore, some of these genes harbor natural polymorphisms that are associated with large differences in sperm competition outcomes (HARSHMAN and PROUT 1994; CLARK *et al.* 1995; FIUMERA *et al.* 2005, 2007), and some of this variation in outcome might be explained by genetic interactions between the sexes.

Sperm competition is characterized by complex genetic interactions, some of which are readily quantified experimentally as male \times female genotypic interaction (CLARK and BEGUN 1998; CLARK *et al.* 1999). A previous small study demonstrated that a male's sperm competitive ability as a first male (his P1 score) or as a second male (his P2 score) depends on the genotype of the female with whom he is mating (CLARK *et al.* 1999). Rank order of male sperm competitive ability depends on female genotype. While male \times female genotypic interactions are known to influence sperm competition outcomes, the generality, magnitude, and specific molecular genetic basis of these interactions are unknown.

In addition to complex male \times female genotypic interactions, both male and female genotypes individually affect sperm competition parameters and other reproductive phenotypes (CLARK *et al.* 1995, 1999; CLARK and BEGUN 1998; FIUMERA *et al.* 2005, 2007; CIVETTA *et al.* 2008). Male genotypic effects have been documented for female remating rate and male P1 score (CLARK *et al.* 1995, 1999; CLARK and BEGUN 1998; FIUMERA *et al.* 2005, 2007; CIVETTA *et al.* 2008). Functional studies of specific Acps are providing us with a good molecular understanding of at least some male contributions to the male \times female interaction (HARSHMAN and PROUT 1994; CHAPMAN *et al.* 2000; WONG *et al.* 2008a; AVILA and WOLFNER 2009; FRICKE *et al.* 2009). However, while female genotypic effects have been documented for the female's egg laying rate and the male's P1 and P2 scores (CLARK *et al.* 1995, 1999; CLARK and BEGUN 1998; FIUMERA *et al.* 2005, 2007; CIVETTA *et al.* 2008), the female molecular contributions to the interactions that underlie sperm competition are unknown.

Only one female protein is known to interact with an Acp: the sex peptide receptor (SPR) (FBgn0029768) interacts with the 36-amino-acid sex peptide (SP) (Acp70A; FBgn0003034) (YAPICI *et al.* 2008). SPR is a G-protein-coupled receptor expressed mainly in the

female reproductive tract, in *fru*⁺ neurons in the brain, and in *fru*⁺*ppk*⁺ neurons of the female reproductive tract. SPR expression in the *fru*⁺*ppk*⁺ neurons innervating the female reproductive tract is necessary and sufficient for egg laying and receptivity changes induced in the female by receipt of SP in the male's seminal fluid (HASEMEYER *et al.* 2009; YANG *et al.* 2009).

In this study, we begin to dissect the genetic architecture of male \times female interactions by examining the interaction between the third chromosome in males and the X chromosome in females. We identify novel male effects, female effects, and male \times female interactions on important measures of reproductive fitness and sperm competition. More importantly, we demonstrate that the third chromosome and the X chromosome have strong individual and interactive effects on the phenotypes measured. We tested for interaction between *SP* and *SPR* and found several intriguing allelic interactions. Our results have important implications for the evolution of male and female reproductive fitness.

MATERIALS AND METHODS

***Drosophila melanogaster* fly cultures:** We used 90 third chromosome extraction lines previously reported (FIUMERA *et al.* 2007) and 51 X chromosome extraction lines previously reported (HILL-BURNS and CLARK 2009). Briefly, each line captures a unique, wild-derived chromosome (3 or X, respectively) and renders it homozygous in a genetic background that is co-isogenic across all lines. Thus, genomes of the X chromosome extraction lines differ only by the X chromosome, and the genomes of the third chromosome extraction lines differ only by the third chromosome. Flies in all chromosome extraction lines have wild-type, red eyes. We sequenced *SP* or *SPR* in the third and X chromosome extraction lines, respectively, and, on the basis of the results, chose 10 lines of each for this study. The experimental lines were chosen to maximize genetic and protein diversity in *SP* and *SPR*. Males from the third chromosome extraction lines and females from the X chromosome extraction lines were used in the sperm competition assays. In the double matings described, second males were from a *bw*^p stock previously described (CLARK and BEGUN 1998). All flies were collected under CO₂ anesthesia and aged 4–7 days in single-sex vials of 20–30 flies. All flies were maintained on standard agar–dextrose–yeast media and housed at 24° on a 12-hr light/dark cycle.

Sperm competition assays: A 10 \times 10 crossing scheme was employed. Males from 10 third chromosome extraction lines were tested against females from 10 X chromosome extraction lines, for a total of 100 separate cross combinations. This design differs from a standard diallel because we are not testing attributes of F₁ flies. Instead this design tests the genetic contribution of the male (third chromosome line) and the female (X chromosome line) in each of the 100 pairwise mating combinations. The progeny are scored for eye color to ascertain the sperm competition and progeny phenotypes of the parental lines. All 100 crosses were replicated 18 times in three separate blocks. For each of the 100 crosses, six males were mass mated to six females for 12 hr (overnight) on day 0 (first mating). On day 1, males were discarded and each female was aspirated into an individual vial (vial 1) and allowed to lay eggs for 24 hr. On day 2, each female was aspirated into a new vial (vial 2) and allowed to lay eggs for 24 hr. On day 3,

each female was aspirated into a new vial (vial 3), and 2 *bw^P* males were placed with each female for 12 hr (overnight; second mating). On day 4, *bw^P* males were discarded and each female was aspirated into a new vial (vial 4) and allowed to lay eggs for 48 hr. On day 6, each female was aspirated into a new vial (vial 5) and allowed to lay eggs for 48 hr. On day 8, females were discarded.

Egg laying rates were scored at 24 and 48 hr after the first mating. Eggs were counted in vials 1 and 2 within 8 hr of removal of females. Total egg count reported is the total number of eggs laid in vials 1 and 2. Progeny were allowed to eclose in vials 1–5 and were scored for eye color. Red-eyed progeny were sired by the third chromosome extraction line male (first male). Brown-eyed progeny were sired by the *bw^P* male (second male). Hatchability/viability is the proportion of eggs that hatched and survived to adulthood (progeny no./egg no. in vials 1 and 2). Remating rate is the proportion of females that remate (of a total of 18 replicates), determined by the presence of one or more brown-eyed progeny in vials 3–5. P1 is the proportion of progeny from the first male after the second mating, calculated as the proportion of red-eyed progeny after the second mating (red/(red + brown)). P1 scores were calculated from vials 4 and 5 of the crosses that remated. Because remating rate was calculated from vials 3–5, a P1 score can be 100% if red-eyed flies were present in vial 3, but not in vials 4 and 5. We did not perform the corresponding P2 experiments for third chromosome extraction line males because no previous studies had implicated a role for *SP* or *SPR* in P2.

We constructed a heat map to visualize the remating rates and P1 scores from the 100 crosses. This provided a quick visualization of the quantitative data. These heat maps are generated in R with the standard `heatmap()` function in the package MASS (VENABLES and RIPLEY 2002). The colors represent remating rates in Figure 1, average P1 scores in Figure 2, and *P*-values for allelic interactions in Figures 3 and 4. We found this to be an effective way to convey differences between genotype combinations, particularly when multiple genotypes are involved in a large sperm competition experiment.

Sequencing: Genomic PCR was performed as in FIUMERA *et al.* (2007). Briefly, genomic DNA was extracted from flies using a standard phenol/chloroform extraction. PCR was performed on the genomic DNA, using gene-specific primers, and products were visualized on 1.5% agarose gels. PCR products were purified with shrimp alkaline phosphatase and exonuclease I (Promega, Madison, WI). The BigDye Termination kit and appropriate sequencing primers were used for automated sequencing (Applied Biosystems, Foster City, CA). The samples were filtered through Sephadex columns (Amersham Biosciences, Piscataway, NJ). Sequencing reaction products were separated and scored on ABI 3730 sequencers by the sequencing facility at the Cornell University Life Sciences Core Laboratories Center.

Primers for the *SP* gene were designed to flank the entire genomic locus to yield an ~500-bp product. The amplified product included both exons, UTRs, and the single intron. Primers for the *SPR* gene were designed to flank the coding exons (exons 3–6). Primers were placed 50–100 bp upstream and downstream of exon/intron boundaries. Exons 1 and 2 of *SPR* are noncoding exons, AT-rich, and difficult to amplify; thus these exons were excluded from analysis. All amplicons were sequenced from both directions.

Sequence traces were manually assembled and examined by eye (Sequencher). Samples containing singleton variants were reamplified and resequenced to ensure that the variant was not a PCR-induced error.

Polymorphisms are denoted by standard methods where a polymorphism in the coding region of a gene is indicated by a 'c' and its nucleotide position from the transcription start site (*e.g.*, c234). Intron polymorphisms are indicated by the number of nucleotides from the start of the intron (*e.g.*, intron 1 + 23). UTR polymorphisms are denoted as the number of nucleotides upstream or downstream of the start or the stop site of transcription, respectively (*e.g.*, 3'-UTR – 15 or 5'-UTR + 15). All polymorphism notations include the major allele followed by the minor allele (*e.g.*, A > T).

Statistical analysis: All statistical analysis was performed in R (version 2.8.1; R Development Core Team). To identify male line, female line, and male × female effects, analysis of variance (ANOVA) was used to apply a simple linear model to each phenotype measured, similar to the analysis described in CLARK *et al.* (1999). These models were applied for each of the phenotypes: egg laying, progeny hatchability, P1 score, and remating rate. The ANOVA model has both random and fixed effects, and so it is a mixed model. The mean of the phenotype (y_{ijk}) for the cross of the *i*th line of male with the *j*th line of female was

$$y_{ijkl} = \mu \times \text{Male}_i \times \text{Female}_j \times (\text{Male} \times \text{Female})_{ij} \times \text{Block}_k \times \varepsilon_{ijkl},$$

where the indexes for the male and the female genotypes are (1, 2, 3, ..., 10) and there were three independent blocks. Recall that there were six replicates of each cross within each block.

To test the significance of interactions between SNPs within *SP* and *SPR*, the lines were recoded on the basis of their SNP genotypes, collapsing the 10 × 10 matrix of effects to 2 × 2 (homozygous lines for either of the two or three SNP alleles at each locus). From these collapsed data, the linear model to test for SNP interactions in egg laying, progeny hatchability, P1 score, and remating rate was

$$y_{ijk} = \mu \times \text{SP}_i \times \text{SPR}_j \times (\text{SP} \times \text{SPR})_{ij} \times \varepsilon_{ijk},$$

where y_{ijk} represents the phenotype of interest. Because there were 12 SNPs in *SP* and 37 in *SPR*, all nonredundant pairwise tests were performed, testing each *SP* polymorphic site for interaction with each polymorphic site in *SPR*. The *SP* × X chromosome and *SPR* × third chromosome tests were performed in a similar manner. Bonferroni correction was applied to infer significance in the face of multiple testing.

Each of the 10 × 10 crosses produces counts of females that successfully remated, and these counts were fitted by a log-linear model (AGRESTI 1990) using the R procedure `loglm`. Log-linear models are like an extension of a chi-square contingency table test, and terms in the model allow explicit testing for whether an interaction between lines or *SP* and *SPR* SNPs affects the counts of the response variable (remating rate). Bonferroni correction was applied to interaction *P*-values to correct for multiple testing. A total of 135 allele interaction tests were performed, rather than 444 tests (12 *SP* polymorphisms × 37 *SPR* polymorphisms) because there were several blocks of polymorphisms in strong linkage disequilibrium in *SP* and *SPR* (supporting information, Table S3 and Table S4).

qPCR: Virgin male and female flies were collected and aged as virgins for 3–5 days. Fifteen flies per line were collected for RNA and flash frozen on dry ice. Total RNA was isolated with a standard phenol/chloroform extraction protocol and stored at –80°. cDNA was synthesized using a Promega kit. qPCR was performed with SYBR green reagents (Roche, Indianapolis). The qPCR reaction was performed on an ABI-7400 instrument and analysis of qPCR data was performed with the ABI Prism 7000 SDS software. *SP* qPCR primers span the exon 1–2

junction. *SPR* qPCR primers span the exon 5–6 junction. *RP49* was used as a stably expressed control gene. Each line's expression was relative to a standard Canton-S laboratory strain. Six measurements were taken of each line: two biological replicates each containing three technical replicates.

Western blots: Western blots were performed as previously reported (LIU and KUBLI 2003). Male reproductive tracts were dissected from 3- to 5-day-old virgin flies. The SP antiserum (LIU and KUBLI 2003) was kindly provided by Eric Kubli.

RESULTS

A 10×10 crossing scheme was employed for a total of 100 double-mating trials. All 100 crosses were replicated 18 times, and of these 1800 trials, 125 were removed because they produced no progeny. A total of 111,002 progeny were counted and scored, and from the progeny phenotypes, we inferred that 847 of the double-mating crosses in fact resulted in females producing progeny from both males. There were doubly mated females for all 100 of the distinct crosses.

Egg laying rate: Egg laying rates after the first mating were scored 24 hr postmating (vial 1) and 48 hr postmating (vial 2). A total of 15,973 eggs (mean \pm SD: 9.8 ± 5.4 per vial) were counted after the first 24 hr and 21,129 eggs (13.1 ± 7.1 per vial) were counted after 48 hr (Figure S1). For both 24 and 48 hr after mating, ANOVA tests indicated a significant male effect (24 hr, $P < 0.0003$; 48 hr, $P < 2.2 \times 10^{-16}$) and a significant female effect (24 hr, $P < 2.2 \times 10^{-16}$; 48 hr, $P < 2.2 \times 10^{-16}$) on egg laying. As expected from previous experience, there was a significant experimental block effect (24 hr, $P < 0.0006$; 48 hr, $P < 0.001$), but no significant male \times female effect was detected for egg laying rate.

Progeny and hatchability/viability: A total of 14,406 progeny (8.7 ± 5.3 per vial) resulted from the eggs counted at 24 hr postmating, and the corresponding count at 48 hr postmating was 18,427 (11.5 ± 7.2 per vial) (Figure S2). For both time points, there was a significant male effect (24 hr, $P < 2.890 \times 10^{-13}$; 48 hr, $P < 2.2 \times 10^{-16}$) and a significant female effect (24 hr, $P < 2.2 \times 10^{-16}$; 48 hr, $P < 2.2 \times 10^{-16}$) on progeny number. There was a marginally significant male \times female effect on progeny number 24 hr after mating ($P < 0.04$), but not 48 hr after mating.

Hatchability/viability for the first mating was calculated from the number of eggs laid and the progeny eclosed for 24 and 48 hr postmating (0.85 ± 0.21 per vial; Figure S3). For 24 and 48 hr postmating, hatchability/viability showed a significant male effect (24 hr, $P < 2.2 \times 10^{-16}$; 48 hr, $P < 2.2 \times 10^{-16}$) and significant female effect (24 hr, $P < 0.0002$; 48 hr, $P < 8.7 \times 10^{-10}$). Similar to egg laying rate, there was a significant male \times female effect for hatchability/viability at 24 hr ($P < 0.021$), but not at 48 hr.

Remating rate: Remating rate was calculated as a proportion of the 18 replicate females that remated within a cross (0.35 ± 0.31 per cross; Figure S4). There

was a significant male effect ($P < 4.03 \times 10^{-13}$) and significant female effect ($P < 0.00038$) on remating. Additionally, a significant male \times female effect was also detected ($P < 0.0005$) (Figure 1).

P1 score: P1 is the proportion of progeny from the first male after the second mating and was calculated from all females that remated with a *bw^P* male. The P1 score (0.20 ± 0.31 per vial) was calculated from 4 days of egg laying, after the second mating (Figure S5). There was a significant male effect ($P < 2.2 \times 10^{-16}$) and significant female effect ($P < 2.18 \times 10^{-5}$). P1 also had the largest male \times female interaction effect of all parameters measured ($P < 1.48 \times 10^{-7}$) (Figure 2).

Polymorphism in *SP* and *SPR*: The entire *SP* genomic locus was sequenced in the 90 third chromosome extraction lines. Sequencing identified 14 sites with segregating polymorphism (Table S1 and Figure S6). One variant was a singleton and 13 variants occurred more than once. Twelve variants were SNPs and 2 variants were indels. One SNP was nonsynonymous and three SNPs were synonymous. The rest of the SNPs and indels were noncoding. There were 16 unique haplotypes represented among the 90 third chromosome extraction lines.

The four coding exons of *SPR* were sequenced in the 51 X chromosome extraction lines. There were a total of 37 polymorphic sites: 35 SNPs and two indels (Table S2 and Figure S7). Six SNPs were singletons and 29 variants occurred more than once. Two SNPs were nonsynonymous and 33 SNPs were synonymous. The rest of the SNPs were noncoding. Both indels occurred in the 5'-UTR. There were 42 unique haplotypes represented among the 51 X chromosome extraction lines.

Ten lines each from the third chromosome and X chromosome extraction lines were chosen for the double-mating experiments described above. The lines were selected to capture as much of the *SP* and *SPR* variation as possible. The third chromosome extraction lines represent nine unique *SP* haplotypes (Table S3). Twelve *SP* polymorphisms are segregating in the 10 third chromosome extraction lines that were used in the mating tests. The X chromosome extraction lines represent nine unique *SPR* haplotypes (Table S4). Thirty-seven *SPR* polymorphisms are segregating in the 10 X chromosome extraction lines that were used in the mating tests.

Associations of polymorphisms in *SP* and *SPR* with reproductive phenotypes: Each polymorphism in *SP* and in *SPR* results in a partitioning of the homozygous lines into two or three groups, one for each of the alternative alleles (one SNP site was segregating with three different nucleotides). We asked whether there is evidence that each polymorphism is associated with differences in the measured phenotypes by performing simple *t*-tests for egg laying rate, progeny phenotypes, and P1 score and chi-square tests for female remating rate. In this study, with the exception of P1 score,

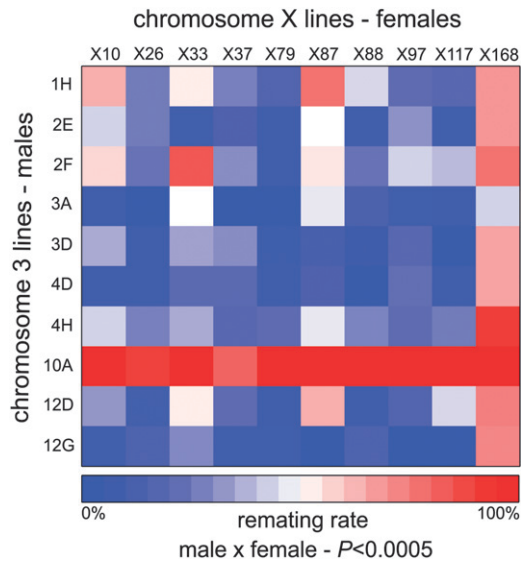


FIGURE 1.—Remating rates are characterized by extensive male \times female interactions. Significant male \times female interactions ultimately determine the female remating rate. Male lines are represented by each row. Female lines are represented by each column. Colors represent remating rates. Significance was tested by a log-linear model.

approximately half of all *SP* and *SPR* polymorphisms have an effect on the phenotypes measured (Table 1, Table S5, and Table S6).

Specific *SP* \times *SPR* interactions: The above tests indicate that several aspects of sperm competition success show a signature of male \times female interaction among the 10 \times 10 lines tested. These lines were chosen to maximize genetic heterogeneity in *SP* and *SPR* and to assess whether *SP* and *SPR* allelic differences played a role in male \times female interactions. We performed an analysis on the basis of the DNA sequence polymorphism within these two genes. By collapsing the lines into categories on the basis of their genotypes at these polymorphic sites, we could then determine the degree of departure from additivity of these genotypes as marginal tests of the full data and assess the likelihood that the *SP* and *SPR* genes are responsible for these effects.

As expected from the lack of male \times female interaction, egg laying rates and the subsequent progeny phenotypes demonstrated no significant *SP* \times *SPR* interactions (data not shown).

The significance of *SP* \times *SPR* interactions on remating rate was assessed by fitting hierarchical log-linear models. Figure 3 shows the resulting uncorrected *P*-values for the interaction terms obtained from these remating tests. While there were 12 interactions that were significant (nominal $P \leq 0.05$), none were significant after correcting for multiple testing.

Figure 4 shows the resulting uncorrected *P*-values for the interaction terms from SNP interaction tests for P1 scores. There were 38 significant *SP* \times *SPR* SNP

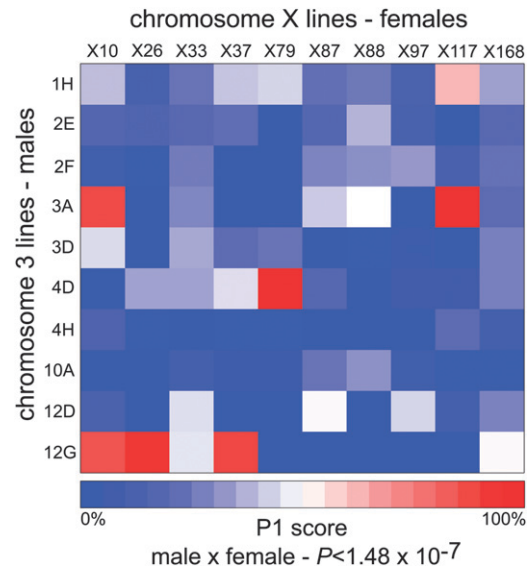


FIGURE 2.—P1 scores are driven by male \times female interactions. Significant male \times female interactions ultimately determine the success of the first male. Male lines are represented by each row. Female lines are represented by each column. Colors represent P1 scores. Significance was tested by a linear model.

interactions (nominal $P \leq 0.05$) and two, in particular, remained significant after correction for multiple testing. The most significant interaction was between an 8-bp deletion in *SP* [intron 1 del(37–44)] and the SNP c567 C > T (L189L) in *SPR* (uncorrected $P = 7.79 \times 10^{-5}$, corrected $P = 0.0105$) (Figure 5A). The female *SPR* genotype at c567 does not have an effect on the P1 score of the deleted *SP* allele; rather, it affects only the P1 score of the wild-type *SP* allele. When the female carries the c567 C *SPR* allele, there is no difference between the P1 scores of males carrying the wild-type or the deleted *SP* allele. However, when females carry the c567 T *SPR* allele, males carrying the wild-type *SP* allele have an eightfold increase in P1 score as compared to males carrying the deleted allele.

There was also a significant interaction effect on P1 scores between the SNP c15 T > C/A (A5A) in *SP* and the SNP c1233 A > G (K411K) in *SPR* (uncorrected $P = 8.23 \times 10^{-5}$, corrected $P = 0.011$) (Figure 5B). When females carry the c1233 A *SPR* allele, males carrying the c15 T *SP* allele have the highest P1 score, followed by males carrying the A allele and males carrying the C allele. However, when females carry the c1233 G *SPR* allele, there is a rank order change and males carrying the c15 A *SP* allele have the highest P1 score, followed by males carrying the T allele and males carrying the C allele. While the success of the male *SPT* and A alleles is affected by female genotype, the success of the C allele is unaffected by female genotype.

We tested whether the interactions observed between *SP* or *SPR* polymorphisms were spurious by testing for interaction with a set of SNPs not thought to be related to

TABLE 1
Proportion of individual *SP* and *SPR* polymorphisms with effects on reproductive phenotypes

Gene	Egg total	Progeny total	Hatchability	Remating rate	P1 score
<i>SP</i>	6/12	11/12	11/12	10/12	9/12
<i>SPR</i>	21/37	15/37	20/37	26/37	6/37

Polymorphisms with significance levels at $P \leq 0.05$ are shown (see Table S5 and Table S6).

Acp3 or Acp processing. *SPR* polymorphisms were tested for interaction with SNPs in 20 immunity genes along the third chromosome (HILL-BURNS and CLARK 2009). There was a deficit of significant P -values between *SPR* and third chromosome SNPs. Seventy-seven of 1548 tests were significant with a nominal $P < 0.05$, but when correction for multiple testing was applied, none of the interactions remained significant. *SP* polymorphisms were also tested for interaction with SNPs in 25 immunity genes along the X chromosome (SACKTON *et al.* 2010). Sixty-one of 636 tests between *SP* and X chromosome polymorphisms were significant with a nominal $P < 0.05$. Again, when correction for multiple testing was applied, none of these interactions remained significant. These data suggest that *SP* and *SPR* polymorphisms interact among themselves at a level that significantly exceeds their degree of interaction with unrelated SNPs.

***SP* and *SPR* expression levels:** Because the majority of polymorphisms identified in the tested lines did not affect the amino acid sequence of *SP* or *SPR*, we hypothesized that they might affect expression levels. Accordingly, we examined expression of *SP* and *SPR*. qPCR was performed for both, and Western blot analysis was performed for *SP*.

qPCR demonstrated that the 10 third chromosome extraction lines differed significantly in their *SP* mRNA levels ($P < 2.2 \times 10^{-16}$) (Figure 6A). There was greater than fourfold difference in normalized *SP* mRNA levels between the lowest-expressing line (4H) and the highest-expressing line (10A). There was no association between *SP* transcript abundance and any of the measured phenotypes, but with only 10 lines, these tests had low power (data not shown). Interestingly, Western blot analysis indicated that degree of variation in protein levels among lines is smaller than the variation in mRNA levels among lines (Figure S8). There is only a twofold difference in *SP* protein level between the lowest-expressing line (12D) and the highest-expressing line (10A). While line 10A displayed the highest *SP* mRNA and protein levels, different lines had the lowest *SP* mRNA levels (4H) and the lowest protein levels (12D). In fact, 12D has the lowest *SP* protein levels, but it displays one of the highest *SP* mRNA levels.

SPR expression levels were evaluated by qPCR only since a suitable *SPR* antibody for Western blotting was not available. qPCR demonstrated that the 10 X chromosome extraction lines differed significantly in their levels of *SPR* mRNA ($P < 2.2 \times 10^{-16}$) (Figure 6B).

There was greater than fivefold difference between the lowest-expressing line (X37) and the highest-expressing line (X26). Similar to the *SP* analysis, there was no significant correlation between *SPR* mRNA levels and the phenotypes measured.

To establish whether the polymorphisms identified in *SP* and *SPR* are associated with mRNA expression differences (eQTL), the lines were categorized according to mean mRNA expression levels and each SNP was tested for an effect of allele on expression level. All polymorphisms carried by only one extraction line were excluded from this analysis. The remaining 5 *SP* polymorphisms demonstrated a significant effect of allele on *SP* mRNA expression (Figure S9). Of the remaining 20 *SPR* polymorphisms, 19 showed a significant effect of allele on *SPR* mRNA expression levels (Figure S9).

DISCUSSION

To examine the genetic architecture of male \times female interactions involved in phenotypes relevant to *Drosophila* reproductive fitness, we measured the interaction between the third chromosome in males and the X chromosome in females. We found that both the third and the X chromosomes have individual main effects on all the reproductive phenotypes measured in this study. In addition, we found that the third and X chromosomes have a large interaction effect on female remating rate and on the sperm competition parameter, P1.

Third chromosome effects: Previous studies (FIUMERA *et al.* 2007) demonstrated that there are multiple significant associations of polymorphisms in male reproductive proteins encoded on chromosome 3 and sperm competition. Our results support this observation. We identified a significant main effect of the third chromosome (male) on female remating rate and P1. Several male reproductive proteins encoded on the third chromosome were previously implicated in affecting either female remating rate or P1. These genes include *CG6168*, *CG14560*, and *SP* (CHAPMAN *et al.* 2003; LIU and KUBLI 2003; FIUMERA *et al.* 2007). Our results suggest that natural variation in these and/or other male reproductive proteins on the third chromosome could contribute to differential sperm competition outcomes.

While whole-genome male effects on fertility phenotypes (egg laying rate, hatchability/viability, and progeny number) have been demonstrated (CIVETTA *et al.*

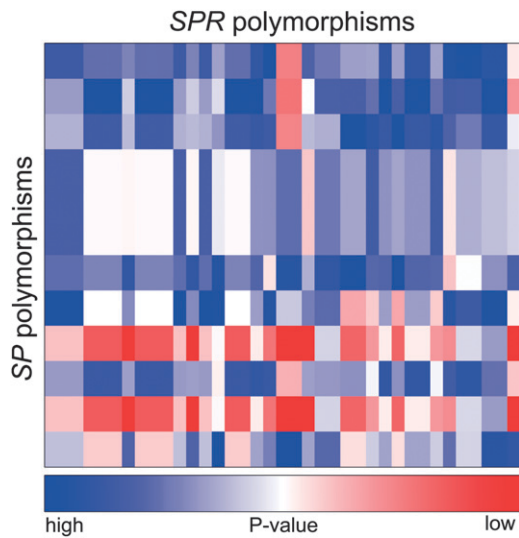


FIGURE 3.—Female remating rates are determined by $SP \times SPR$ polymorphism interactions. Polymorphisms in SP interact with polymorphisms in SPR to give the female remating rate. Male SP polymorphisms are represented by rows and female SPR polymorphisms are represented by columns. Several SP polymorphisms are in linkage disequilibrium and several SPR polymorphisms are in linkage disequilibrium, reducing the total number of interactions possible. Colors represent the uncorrected P -value of each interaction. Dark blue represents higher P -value, less significant interactions. Dark red represents lower P -value, more significant interactions. Significance was tested by a log-linear model.

2008), individual chromosomes have not previously been examined for their contributions to this male effect. We demonstrate that the third chromosome (male) has significant effects on all these fertility phenotypes. The third chromosome harbors several male reproductive genes that have a demonstrated role in egg production, including *DUP99B* (SAUDAN *et al.* 2002), *CG33943* (RAVIRAM and WOLFNER 2007b), and *SP* (CHAPMAN *et al.* 2003; LIU and KUBLI 2003). Polymorphism in any of these genes could potentially contribute to the third chromosome effect we observe. To test this hypothesis, we sequenced these genes in the 10 third chromosome lines. We identified very few polymorphisms in *DUP99B* and *CG33943*, and all the variants we found were noncoding or synonymous, with no predicted functional consequences for the proteins (data not shown). The results for *SP* are discussed below. These data suggest that a large effect arising from *DUP99B* and *CG33943* is not likely to underlie the variation in fertility phenotypes we observed. Instead, combined small effects of many genes or an as yet unidentified gene of large effect might explain the third chromosome effect. These data motivate the continued search for the functional role of male reproductive genes on the third chromosome.

X chromosome effects: Past studies demonstrated a strong female effect on fertility phenotypes (CIVETTA *et al.* 2008) and P1 (CLARK *et al.* 1999), but the female effect on female remating was not tested. Our results

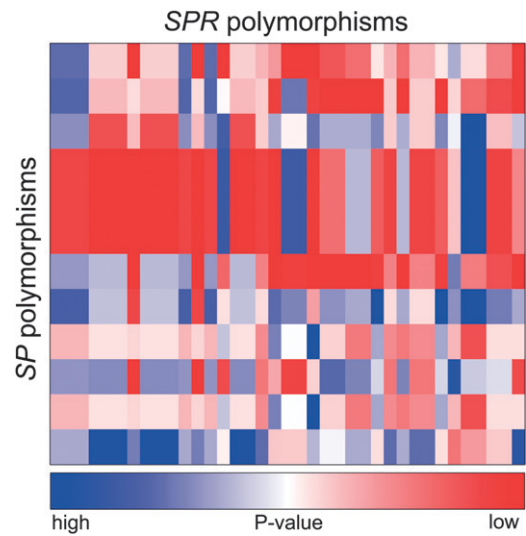


FIGURE 4.— $SP \times SPR$ polymorphism interactions in P1. Polymorphisms in SP interact with polymorphisms in SPR to give the final P1 score of each genotypic pair. Male SP polymorphisms are represented by rows and female SPR polymorphisms are represented by columns. Several SP polymorphisms are in linkage disequilibrium and several SPR polymorphisms are in linkage disequilibrium, reducing the total number of interactions possible. Colors represent the uncorrected P -value of each interaction. Dark blue represents higher P -value, less significant interactions. Dark red represents lower P -value, more significant interactions. Significance was tested by a log-linear model.

show a strong female effect on remating rate. Furthermore, we demonstrate a strong X chromosome female effect on all the phenotypes measured.

The X chromosome harbors at least one female gene with an important role in female remating rate and fertility phenotypes, *SPR* (YAPICI *et al.* 2008). Variation in *SPR* might have a direct influence on these phenotypes. Although little is known about other female molecules important for female remating rate, *SPR* is likely not to be the only X chromosome gene to affect fertility phenotypes we measured; for example, numerous female molecules are known to affect egg laying. The process of egg production and egg laying takes place within the female reproductive tract, and although ovulation is stimulated by mating, the egg must progress through the female reproductive tract, encountering muscle contractions and neuroendocrine signals before fertilization can occur (reviewed in BLOCH QAZI *et al.* 2003).

We observed an X chromosome female effect on P1, but it is not known which genes on the X chromosome might contribute to this effect. Variation in P1 requires that the female modulate her sperm usage from the first and the second male. This suggests that at least some female genes involved in sperm usage reside on the X chromosome. Identification of these genes would further elucidate the female's contribution to variation in P1. Candidate genes might include X-linked genes that are expressed in sperm storage organs in the female,

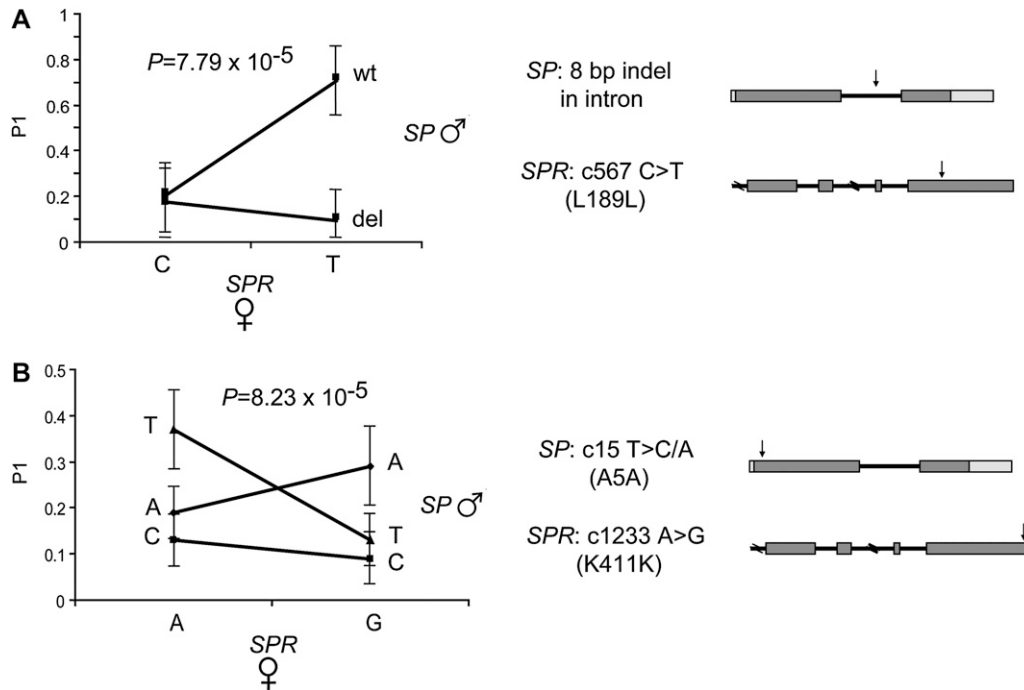


FIGURE 5.—Polymorphism interactions between *SP* and *SPR*. The two most significant interactions between *SP* and *SPR* are shown. (A) An intronic indel in *SP* interacts with a synonymous SNP in *SPR*. The P1 score of the male alleles is dependent on the female allele. Males have similar P1 scores when females carry the *SPR* C allele. However, there is an approximately eightfold difference in P1 scores between the male *SP* alleles when the female carries the *SPR* T allele. (B) A synonymous SNP in *SP* interacts with a synonymous SNP in *SPR*. The rank order of male *SP* allele changes dependent on the female *SPR* allele. Significance was tested by a log-linear model.

including the spermathecae and the seminal receptacle (ALLEN and SPRADLING 2008; PROKUPEK *et al.* 2008, 2009, 2010).

Chromosome interactions: In addition to separate male and female effects, we identified male \times female genotypic interactions for female remating rate. This is the first documentation of an effect of interaction between the genotypes of both sexes on the female's willingness to remate. Two lines had strong individual sex effects on female remating rate. One line (third chromosome line 10A) demonstrated a male-only effect on remating rate, irrespective of female genotype. Males from this line are poor at preventing remating and must be carrying polymorphism on the third chromosome that affects one or more reproductive proteins. Another line (X chromosome line X168) showed a female-only effect on remating rate, suggesting that its X chromosome harbors polymorphisms that supersede effects of male genotype.

The strong male \times female interactions that we identified are consistent with results from a smaller study (CLARK *et al.* 1999), and we extend it by doubling the number of lines used, including lines from a different population, and, most importantly, examining the interaction between two specific chromosomes. Our results indicate that male \times female interactions are not unique to the previously examined lines. The robust interactions identified in both studies show that interaction between the genotypes is critical to sperm competition outcomes.

While other studies reported male \times female genotype interactions in fertility phenotypes (CIVETTA *et al.* 2008), we did not detect such an interaction. There are many possible explanations for the difference in findings across studies. First, environmental conditions can have a very large effect on egg laying rates (MCGRAW

et al. 2007; FRICKE *et al.* 2010), and it is almost certain the conditions of our study differed from those of the earlier study. Second, the experimental design we employed involved egg counts only on the first 2 days after the first mating, whereas the study reported egg counts over a longer period. Third, because the studies utilized very different experimental lines, we may not have captured polymorphisms that show interactive effects.

We limited our analysis to the third chromosome in males and the X chromosome in females, whereas CIVETTA *et al.* (2008) and CLARK *et al.* (1999) did not focus on specific interchromosomal interactions. We found that the third and X chromosomes showed strong interaction for female remating rate and P1. However, genes on the second and fourth chromosomes, as well as male genes on the X chromosome and female genes on the third chromosome, could also potentially interact. Our design eliminated variation on the second and fourth chromosomes, and the primary goal was to determine interaction between the two chromosomes harboring *SP* and *SPR*. We expect there may be additional interactions involving genes throughout the genome.

***SP* \times *SPR* interactions:** By examining the third chromosome in males and the X chromosome in females, we had the unique opportunity to test for potential interaction between two known physically interacting proteins. *SP* and *SPR* are the only two known male/female *Drosophila* reproductive genes whose protein products physically interact (YAPICI *et al.* 2008). *SP* is on the third chromosome and its protein is transferred to the female during mating. In the female, *SP* binds its X-encoded receptor *SPR*, and this physical interaction

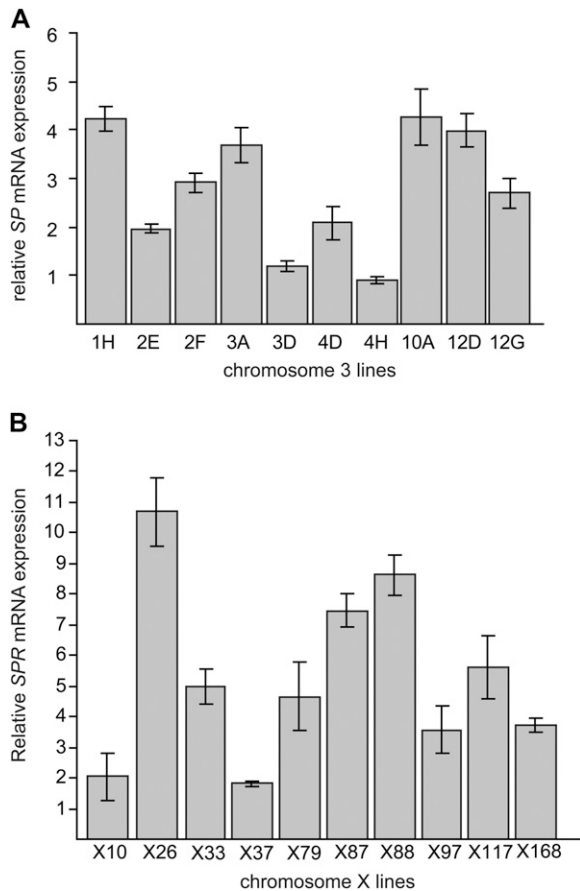


FIGURE 6.—*SP* and *SPR* mRNA expression varies across lines. mRNA expression was quantified by qPCR. (A) *SP* expression in male third chromosome extraction lines significantly differs ($P < 2.2 \times 10^{-16}$). (B) *SPR* expression in female X chromosome extraction lines significantly differs ($P < 2.2 \times 10^{-16}$). Levels of mRNA are expressed relative to a standard Canton-S laboratory strain. All measurements consist of six measurements, two biological replicates containing three technical replicates each. Mean \pm SD is shown.

results in many postmating changes in the female, potentially affecting all the phenotypes measured in this study (YAPICI *et al.* 2008).

We tested the interaction of each *SP* polymorphism with each *SPR* polymorphism for all phenotypes measured in this study. We found no *SP* \times *SPR* interactions for fertility phenotypes or remating rates, but this may be explained by the reasons discussed above (in *Chromosome interactions*). We found two very significant interactions between *SP* and *SPR* alleles for P1. In one case, the two male *SP* alleles display an eightfold difference in P1 depending on the female *SPR* allele. In another case, there is a rank-order change between the two male *SP* alleles in P1, dependent on the female *SPR* allele.

While these statistical observations are intriguing, they are only suggestive of biologically relevant allelic interactions given that the effects are detected from only 10 lines for each extracted chromosome, and the

extracted chromosomes are segregating at many other sites. However, the observation of interaction among *SP* and *SPR* alleles makes sense in light of previous work. First, FRICKE *et al.* (2009) presented evidence that *SP* might have a role in sperm competition. Second, *SP* function is required for proper release of stored sperm from female sperm storage organs (AVILA *et al.* 2010). Inappropriate release of sperm from storage organs can have a direct effect on sperm usage and P1 scores (AVILA and WOLFNER 2009; RAM and WOLFNER 2009). Furthermore, we demonstrate that *SP* alleles do not spuriously interact with unrelated polymorphisms along the X chromosome and similarly, *SPR* alleles do not interact with polymorphisms in non-reproduction-related genes along the third chromosome. Finally, in our tested lines, each *SP* and *SPR* allele is carried on multiple haplotypes (at least three for most alleles), reducing the potential for an interaction with a linked variant. We recognize that this is not definitive proof of allelic interactions between *SP* and *SPR*, but these observations motivate future functional testing of the interaction between these and other potential interacting *SP* and *SPR* alleles.

Evolutionary implications: Interactive genotypic effects between the sexes described here and elsewhere (CLARK *et al.* 1999; CIVETTA *et al.* 2008) could lead to alleles in interacting genes exhibiting dynamic cycling behavior that could protect and maintain polymorphism (CLARK 2002). In agreement with this theory, some *Acp*s display nonneutral patterns of evolution and high levels of polymorphism (CIRERA and AGUADE 1997, 1998; TSAUR and WU 1997; AGUADE 1998, 1999; CLARK and BEGUN 1998; TSAUR *et al.* 1998; SWANSON *et al.* 2001; HAERTY *et al.* 2007; WONG *et al.* 2008b; KELLEHER and MARKOW 2009). Rapid evolution has been observed for some genes expressed in the female reproductive tract, which might potentially encode *Acp* receptors and proteins involved in postmating responses (SWANSON *et al.* 2004; PROKUPEK *et al.* 2008, 2010). In a wild population, many male alleles may be segregating and their success will depend on the genotype of the female receptor/response gene.

Male \times female genetic interactions might underlie the maintenance of variation in sperm competition success. Differences in sperm competition success likely reflect the interaction between allelic variation in critical genes. Rather than single, optimal alleles becoming fixed, this allelic variation could be maintained due to a variety of selective forces. For example, some aspects of sperm competition ability and female responses have been proposed to be under sexually antagonistic selection (PARKER 1970). In this scenario, differing interests between the sexes may prevent fixation of an allele favorable to individuals of one sex but detrimental to individuals of the other sex. In another scenario, postcopulatory sexual selection (EBERHARD 1996) could also maintain allelic variation, particularly in the context of cryptic female choice. If

females of certain genotypes preferentially use sperm of select male genotypes, multiple combinations of male and female genotypes might have equivalent fitness and thus would all be maintained. It is unknown which of these or other scenarios are the driving force behind variation we see in sperm competition ability or in the allelic variation in *SP* and *SPR*, but the abundance of empirical evidence for male \times female interaction leaves open these mechanisms as potentially critical aspects of the evolution of sperm competitive ability.

The X chromosome differs from autosomes in that it spends two-thirds (rather than half) of the time in females. This has permitted the “feminization” of the X chromosome (RICE 1984), in that the X chromosome carries a relative excess of female-expressed genes (PARISI *et al.* 2003; RANZ *et al.* 2003; GURBICH and BACHTROG 2008), whereas male-biased genes are skewed to the autosomes. Because female genes on the X chromosome are under stronger selection in the female, we might expect that sperm-competition-related female genes on the X chromosome are particularly poised to coevolve with male effects arising from male-expressed autosomal genes.

The data presented here motivate further study of the complex genetic architecture of sperm competition. Only when we identify the genes involved on both sides of the interaction, can we begin to understand the dynamic evolution of this important system.

We thank D. Castillo for his help with scoring flies. We thank L. Sirot, F. Avila, T. Connallon, and T. Greenberg for helpful comments. We thank A. Fiumera for discussions. We thank E. Kubli for kindly providing anti-SP and N. Yapici, Y.-J. Kim, and B. Dickson for helpful discussions and a sample of anti-SPR. We thank Montserrat Aguadé and four anonymous reviewers for suggestions that greatly improved this report. This work was funded by National Institutes of Health (NIH)/National Institute of Child Health and Human Development (NICHD) grant R01-HD059060 (to M.F.W. and A.G.C.), NIH/NICHD grant R01-HD038921 (to M.F.W.), National Science Foundation grant DEB-0743125 (to A.G.C.), and NIH/NICHD training grant in reproductive genomics T32-HD052471 (to C.Y.C.).

LITERATURE CITED

- AGRESTI, A., 1990 *Categorical Data Analysis*. John Wiley & Sons, New York.
- AGUADÉ, M., 1998 Different forces drive the evolution of the Acp26Aa and Acp26Ab accessory gland genes in the *Drosophila melanogaster* species complex. *Genetics* **150**: 1079–1089.
- AGUADÉ, M., 1999 Positive selection drives the evolution of the Acp29AB accessory gland protein in *Drosophila*. *Genetics* **152**: 543–551.
- AGUADÉ, M., N. MIYASHITA and C. LANGLEY, 1992 Polymorphism and divergence in the *Mst26A* male accessory gland gene region in *Drosophila*. *Genetics* **132**: 755–770.
- ALLEN, A. K., and A. C. SPRADLING, 2008 The Sfl-related nuclear hormone receptor Hr39 regulates *Drosophila* female reproductive tract development and function. *Development* **135**: 311–321.
- AVILA, F. W., and M. F. WOLFNER, 2009 Acp36DE is required for uterine conformational changes in mated *Drosophila* females. *Proc. Natl. Acad. Sci. USA* **106**: 15796–15800.
- AVILA, F. W., K. RAVI RAM, M. C. BLOCH QAZI and M. F. WOLFNER, 2010 Sex peptide is required for the efficient release of stored sperm in mated *Drosophila* females. *Genetics* **186**: 595–600.
- BEGUN, D. J., and H. A. LINDFORS, 2005 Rapid evolution of genomic Acp complement in the *melanogaster* subgroup of *Drosophila*. *Mol. Biol. Evol.* **22**: 2010–2021.
- BLOCH QAZI, M. C., Y. HEIFETZ and M. F. WOLFNER, 2003 The developments between gametogenesis and fertilization: ovulation and female sperm storage in *Drosophila melanogaster*. *Dev. Biol.* **256**: 195–211.
- CHAPMAN, T., D. M. NEUBAUM, M. F. WOLFNER and L. PARTRIDGE, 2000 The role of male accessory gland protein Acp36DE in sperm competition in *Drosophila melanogaster*. *Proc. R. Soc. Lond.* **267**: 1097–1105.
- CHAPMAN, T., J. BANGHAM, G. VINTI, B. SEIFRIED, O. LUNG *et al.*, 2003 The sex peptide of *Drosophila melanogaster*: female post-mating responses analyzed by using RNA interference. *Proc. Natl. Acad. Sci. USA* **100**: 9923–9928.
- CIRERA, S., and M. AGUADÉ, 1997 Evolutionary history of the sex-peptide (Acp70A) gene region in *Drosophila melanogaster*. *Genetics* **147**: 189–197.
- CIRERA, S., and M. AGUADÉ, 1998 Molecular evolution of a duplication: the sex-peptide (Acp70A) gene region of *Drosophila subobscura* and *Drosophila madeirensis*. *Mol. Biol. Evol.* **15**: 988–996.
- CIVETTA, A., and R. S. SINGH, 1998 Sex-related genes, directional sexual selection, and speciation. *Mol. Biol. Evol.* **15**: 901–909.
- CIVETTA, A., K. ROSING and J. FISHER, 2008 Differences in sperm competition and sperm competition avoidance in *Drosophila melanogaster*. *Anim. Behav.* **75**: 1739–1746.
- CLARK, A. G., 2002 Sperm competition and the maintenance of polymorphism. *Heredity* **88**: 148–153.
- CLARK, A. G., and D. J. BEGUN, 1998 Female genotypes affect sperm displacement in *Drosophila*. *Genetics* **149**: 1487–1493.
- CLARK, A. G., M. AGUADÉ, T. PROUT, L. G. HARSHMAN and C. H. LANGLEY, 1995 Variation in sperm displacement and its association with accessory gland protein loci in *Drosophila melanogaster*. *Genetics* **139**: 189–201.
- CLARK, A. G., D. J. BEGUN and T. PROUT, 1999 Female \times male interactions in *Drosophila* sperm competition. *Science* **283**: 217–220.
- EBERHARD, W. G., 1996 *Female Control: Sexual Selection by Cryptic Female Choice*. Princeton University Press, Princeton, NJ.
- FINDLAY, G. D., X. YI, M. J. MACCOSS and W. J. SWANSON, 2008 Proteomics reveals novel *Drosophila* seminal fluid proteins transferred at mating. *PLoS Biol.* **6**: e178.
- FINDLAY, G. D., M. J. MACCOSS and W. J. SWANSON, 2009 Proteomic discovery of previously unannotated, rapidly evolving seminal fluid genes in *Drosophila*. *Genome Res.* **19**: 886–896.
- FIUMERA, A. C., B. L. DUMONT and A. G. CLARK, 2005 Sperm competitive ability in *Drosophila melanogaster* associated with variation in male reproductive proteins. *Genetics* **169**: 243–257.
- FIUMERA, A. C., B. L. DUMONT and A. G. CLARK, 2007 Associations between sperm competition and natural variation in male reproductive genes on the third chromosome of *Drosophila melanogaster*. *Genetics* **176**: 1245–1260.
- FRICKE, C., S. WIGBY, R. HOBBS and T. CHAPMAN, 2009 The benefits of male ejaculate sex peptide transfer in *Drosophila melanogaster*. *J. Evol. Biol.* **22**: 275–286.
- FRICKE, C., A. BRETMAN and T. CHAPMAN, 2010 Female nutritional status determines the magnitude and sign of responses to a male ejaculate signal in *Drosophila melanogaster*. *J. Evol. Biol.* **23**: 157–165.
- GURBICH, T. A., and D. BACHTROG, 2008 Gene content evolution on the X chromosome. *Curr. Opin. Genet. Dev.* **18**: 493–498.
- HAERTY, W., S. JAGADEESHAN, R. J. KULATHINAL, A. WONG, K. RAVI RAM *et al.*, 2007 Evolution in the fast lane: rapidly evolving sex-related genes in *Drosophila*. *Genetics* **177**: 1321–1335.
- HARSHMAN, L. G., and A. G. CLARK, 1998 Inference of sperm competition from broods of field-caught *Drosophila*. *Evolution* **52**: 1334–1341.
- HARSHMAN, L. G., and T. PROUT, 1994 Sperm displacement without sperm transfer in *Drosophila melanogaster*. *Evolution* **48**: 758–766.
- HASEMEYER, M., N. YAPICI, U. HEBERLEIN and B. J. DICKSON, 2009 Sensory neurons in the *Drosophila* genital tract regulate female reproductive behavior. *Neuron* **61**: 511–518.
- HILL-BURNS, E. M., and A. G. CLARK, 2009 X-linked variation in immune response in *Drosophila melanogaster*. *Genetics* **183**: 1477–1491.
- HUGHES, K. A., 1997 Quantitative genetics of sperm precedence in *Drosophila melanogaster*. *Genetics* **145**: 139–151.
- IMHOF, M., B. HARR, G. BREM and C. SCHLOTTERER, 1998 Multiple mating in wild *Drosophila melanogaster* revisited by microsatellite analysis. *Mol. Ecol.* **7**: 915–917.

- ISAAC, R. E., C. LI, A. E. LEEDALE and A. D. SHIRRAS, 2010 *Drosophila* male sex peptide inhibits siesta sleep and promotes locomotor activity in the post-mated female. *Proc. Biol. Sci.* **277**: 65–70.
- KELLEHER, E. S., and T. A. MARKOW, 2009 Duplication, selection and gene conversion in a *Drosophila mojavensis* female reproductive protein family. *Genetics* **181**: 1451–1465.
- LIU, H., and E. KUBLI, 2003 Sex-peptide is the molecular basis of the sperm effect in *Drosophila melanogaster*. *Proc. Natl. Acad. Sci. USA* **100**: 9929–9933.
- MCGRAW, L. A., A. C. FIUMERA, M. RAMAKRISHNAN, S. MADHAVARAPU, A. G. CLARK *et al.*, 2007 Larval rearing environment affects several post-copulatory traits in *Drosophila melanogaster*. *Biol. Lett.* **3**: 607–610.
- MUELLER, J. L., K. RAVI RAM, L. A. MCGRAW, M. C. BLOCH QAZI, E. D. SIGGIA *et al.*, 2005 Cross-species comparison of *Drosophila* male accessory gland protein genes. *Genetics* **171**: 131–143.
- PARISI, M., R. NUTTALL, D. NAIMAN, G. BOUFFARD, J. MALLEY *et al.*, 2003 Paucity of genes on the *Drosophila* X chromosome showing male-biased expression. *Science* **299**: 697–700.
- PARKER, G. A., 1970 Sperm competition and its evolutionary consequences in the insects. *Biol. Rev.* **45**: 525–567.
- PROKUPEK, A., F. HOFFMANN, S. I. EYUN, E. MORIYAMA, M. ZHOU *et al.*, 2008 An evolutionary expressed sequence tag analysis of *Drosophila* spermatheca genes. *Evolution* **62**: 2936–2947.
- PROKUPEK, A. M., S. D. KACHMAN, I. LADUNGA and L. G. HARSHMAN, 2009 Transcriptional profiling of the sperm storage organs of *Drosophila melanogaster*. *Insect Mol. Biol.* **18**: 465–475.
- PROKUPEK, A. M., S. I. EYUN, L. KO, E. N. MORIYAMA and L. G. HARSHMAN, 2010 Molecular evolutionary analysis of seminal receptacle sperm storage organ genes of *Drosophila melanogaster*. *J. Evol. Biol.* **23**: 1386–1398.
- RAM, K. R., and M. F. WOLFNER, 2009 A network of interactions among seminal proteins underlies the long-term postmating response in *Drosophila*. *Proc. Natl. Acad. Sci. USA* **106**: 15384–15389.
- RANZ, J. M., C. I. CASTILLO-DAVIS, C. D. MEIKLEJOHN and D. L. HARTL, 2003 Sex-dependent gene expression and evolution of the *Drosophila* transcriptome. *Science* **300**: 1742–1745.
- RAVI RAM, K., and M. F. WOLFNER, 2007a Seminal influences: *Drosophila* Acps and the molecular interplay between males and females during reproduction. *Integr. Comp. Biol.* **47**: 427–445.
- RAVI RAM, K., and M. F. WOLFNER, 2007b Sustained post-mating response in *Drosophila melanogaster* requires multiple seminal fluid proteins. *PLoS Genet.* **3**: e238.
- RICE, W. R., 1984 Sex chromosome and the evolution of sexual dimorphism. *Evolution* **38**: 735–742.
- SACKTON, T. B., B. P. LAZZARO and A. G. CLARK, 2010 Genotype and gene expression associations with immune function in *Drosophila*. *PLoS Genet.* **6**: e1000797.
- SAUDAN, P., K. HAUCK, M. SOLLER, Y. CHOFFAT, M. OTTIGER *et al.*, 2002 Ductus ejaculatorius peptide 99B (DUP99B), a novel *Drosophila melanogaster* sex-peptide pheromone. *Eur. J. Biochem.* **269**: 989–997.
- SWANSON, W. J., and V. D. VACQUIER, 2002 The rapid evolution of reproductive proteins. *Nat. Rev. Genet.* **3**: 137–144.
- SWANSON, W. J., A. G. CLARK, H. M. WALDRIP-DAIL, M. F. WOLFNER and C. F. AQUADRO, 2001 Evolutionary EST analysis identifies rapidly evolving male reproductive proteins in *Drosophila*. *Proc. Natl. Acad. Sci. USA* **98**: 7375–7379.
- SWANSON, W. J., A. WONG, M. F. WOLFNER and C. F. AQUADRO, 2004 Evolutionary EST analysis of *Drosophila* female reproductive tracts identifies several genes subjected to positive selection. *Genetics* **168**: 1457–1465.
- TSAUR, S. C., and C.-I. WU, 1997 Positive selection and the molecular evolution of a gene of male reproduction, Acp26Aa of *Drosophila*. *Mol. Biol. Evol.* **14**: 544–549.
- TSAUR, S. C., C. T. TING and C.-I. WU, 1998 Positive selection driving the evolution of a gene of male reproduction, Acp26Aa, of *Drosophila*: II. Divergence versus polymorphism. *Mol. Biol. Evol.* **15**: 1040–1046.
- VENABLES, W. N., and B. D. RIPLEY, 2002 *Modern Applied Statistics with S*. Springer, New York.
- WOLFNER, M. F., 2009 Battle and ballet: molecular interactions between the sexes in *Drosophila*. *J. Hered.* **100**: 399–410.
- WONG, A., S. N. ALBRIGHT, J. D. GIEBEL, K. R. RAM, S. JI *et al.*, 2008a A role for Acp29AB, a predicted seminal fluid lectin, in female sperm storage in *Drosophila melanogaster*. *Genetics* **180**: 921–931.
- WONG, A., M. C. TURCHIN, M. F. WOLFNER and C. F. AQUADRO, 2008b Evidence for positive selection on *Drosophila melanogaster* seminal fluid protease homologs. *Mol. Biol. Evol.* **25**: 497–506.
- YANG, C. H., S. RUMPF, Y. XIANG, M. D. GORDON, W. SONG *et al.*, 2009 Control of the postmating behavioral switch in *Drosophila* females by internal sensory neurons. *Neuron* **61**: 519–526.
- YAPICI, N., Y. J. KIM, C. RIBEIRO and B. J. DICKSON, 2008 A receptor that mediates the post-mating switch in *Drosophila* reproductive behaviour. *Nature* **451**: 33–37.

GENETICS

Supporting Information

<http://www.genetics.org/cgi/content/full/genetics.110.123174/DC1>

The Genetic Basis for Male × Female Interactions Underlying Variation in Reproductive Phenotypes of *Drosophila*

Clement Y. Chow, Mariana F. Wolfner and Andrew G. Clark

Copyright © 2010 by the Genetics Society of America
DOI: 10.1534/genetics.110.123174

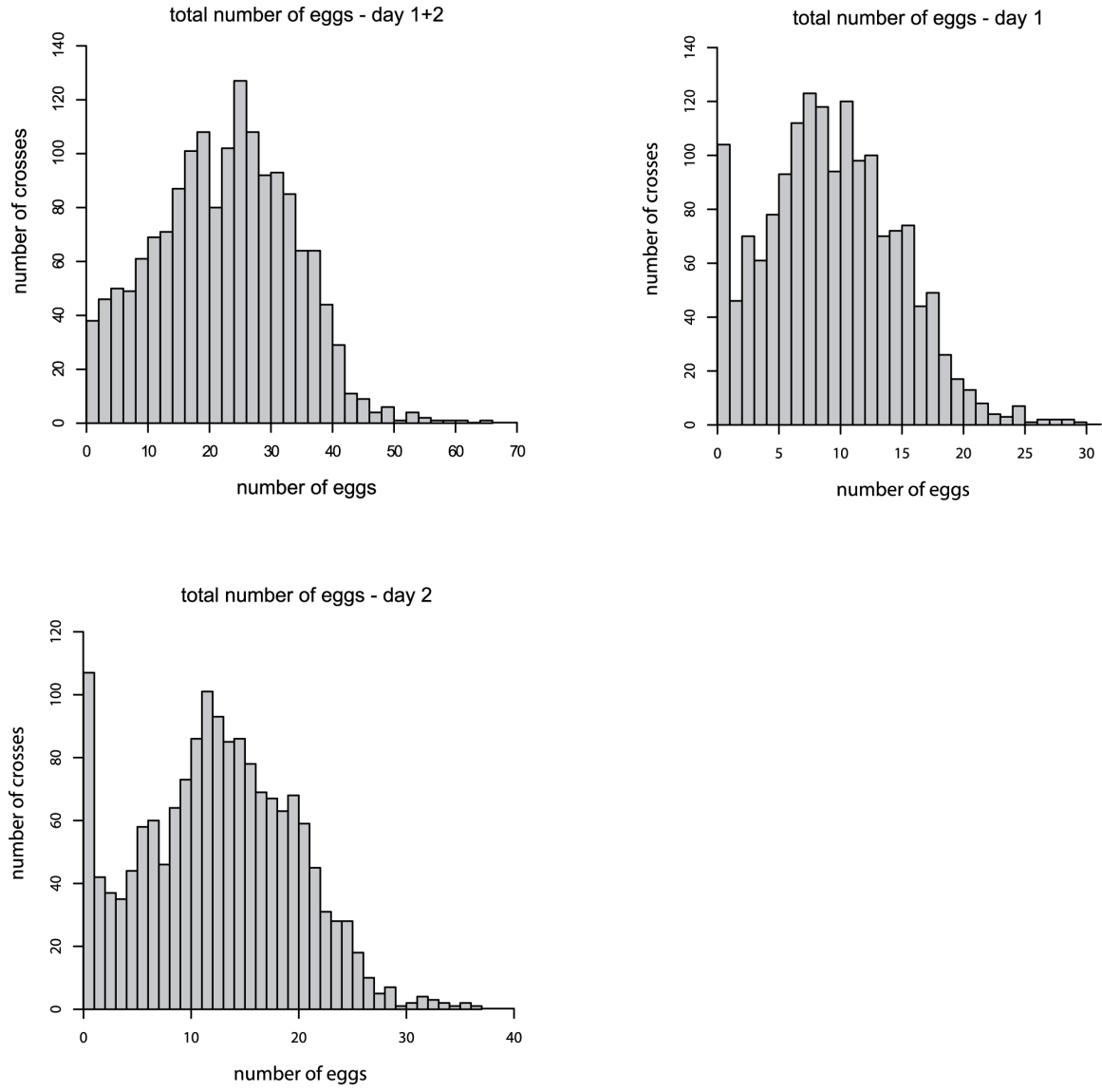


FIGURE S1.—Egg counts. Number of eggs counted during the first two days after first mating.

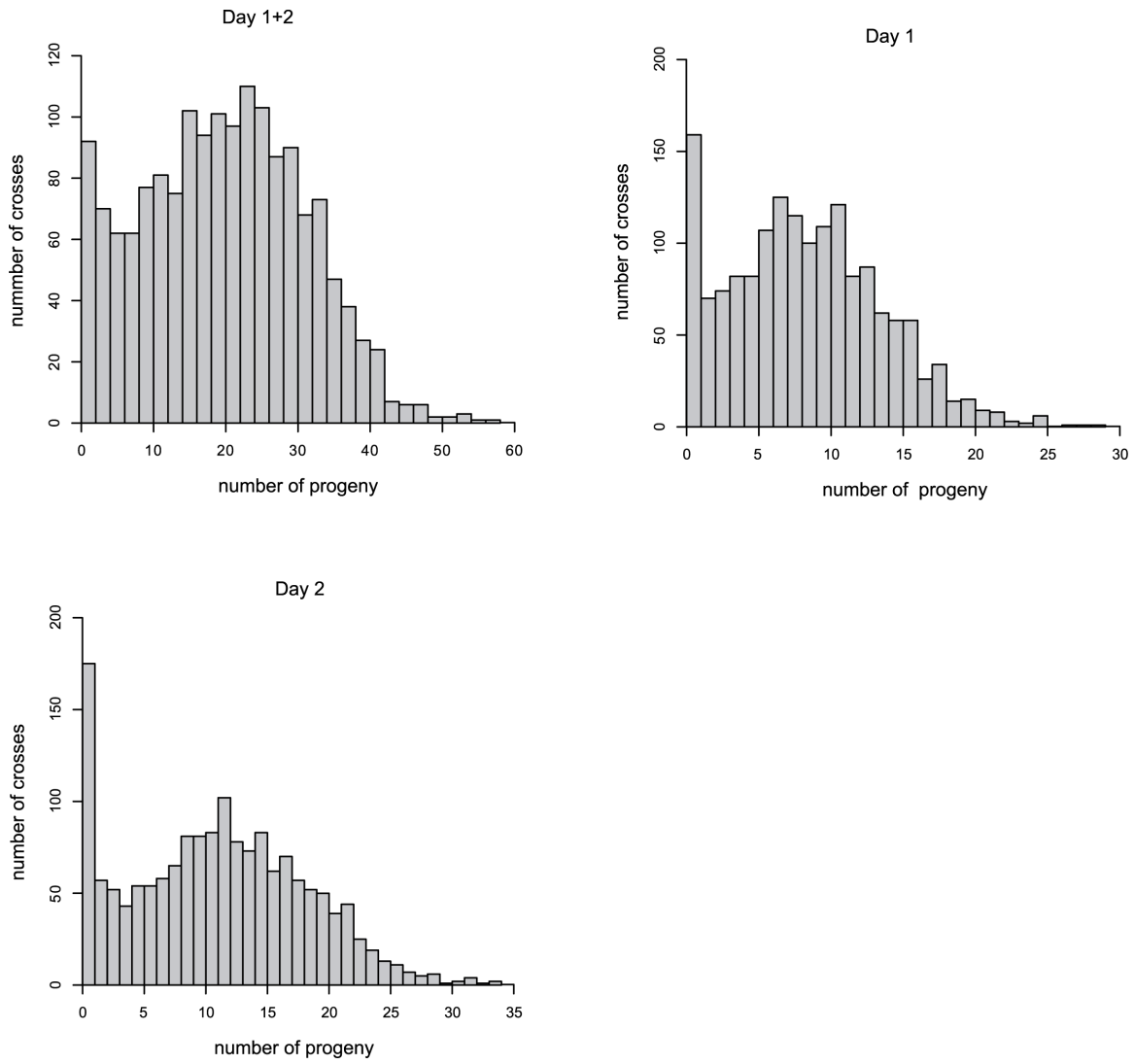


FIGURE S2.—Progeny counts. Number of progeny counted during the first two days after first mating.

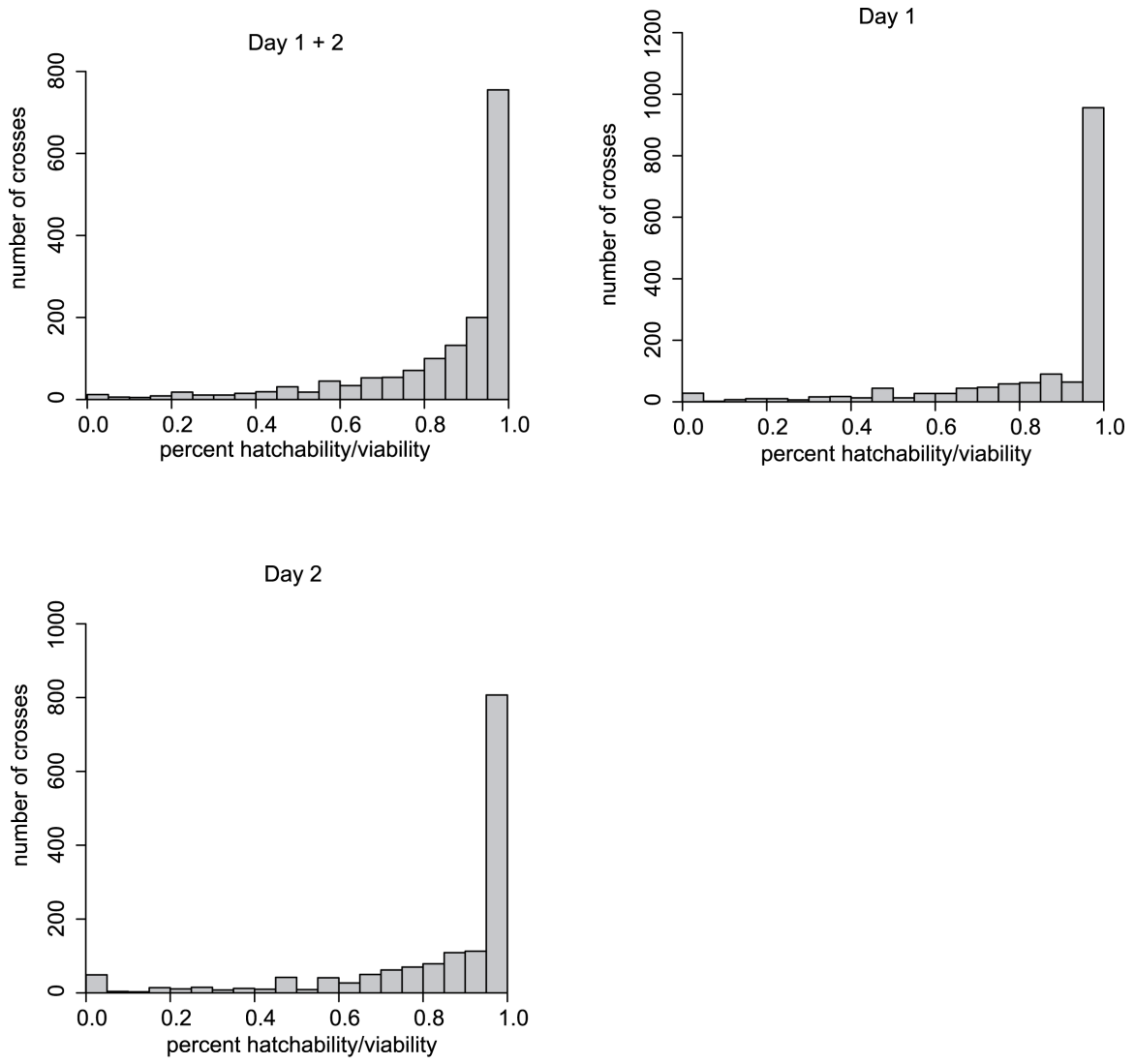


FIGURE S3.—Hatchability/viability. Hatchability/viability values during the first two days after first mating.

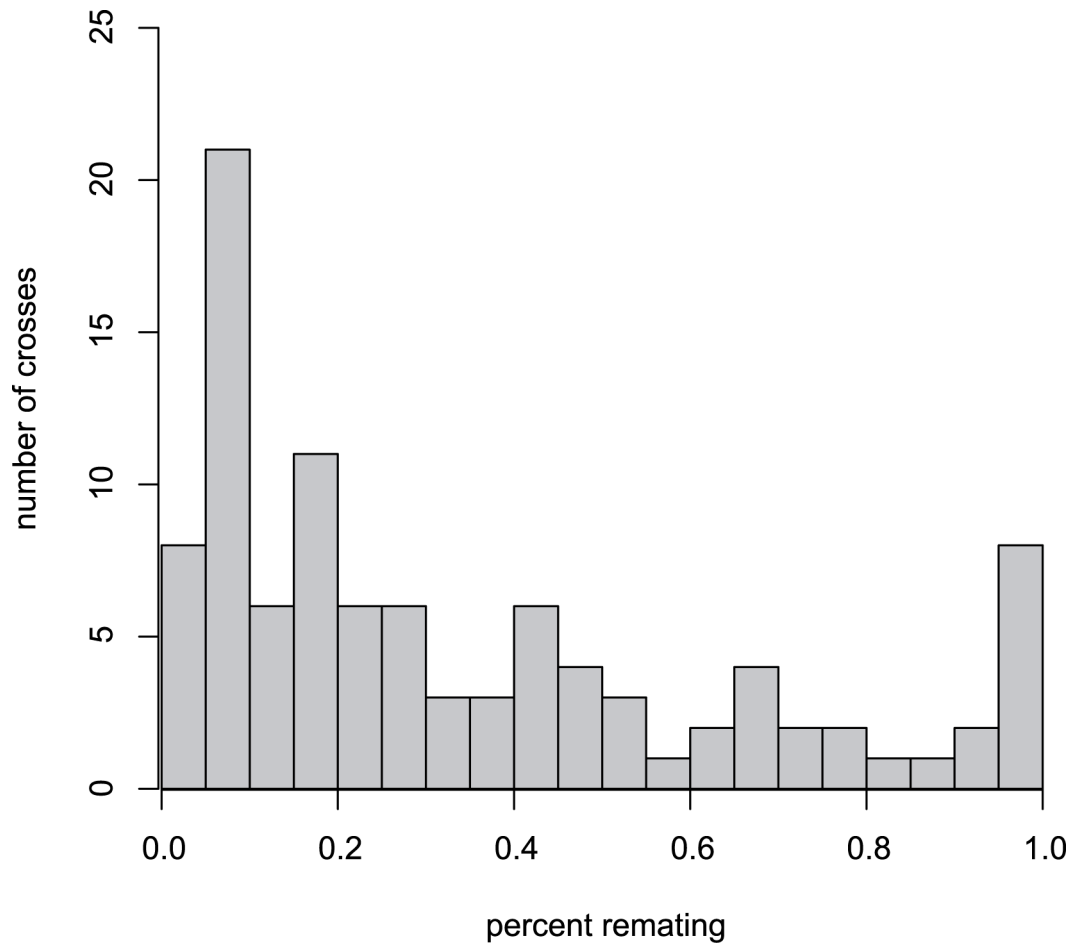


FIGURE S4.—Remating rates. Mean remating rates of all 100 crosses.

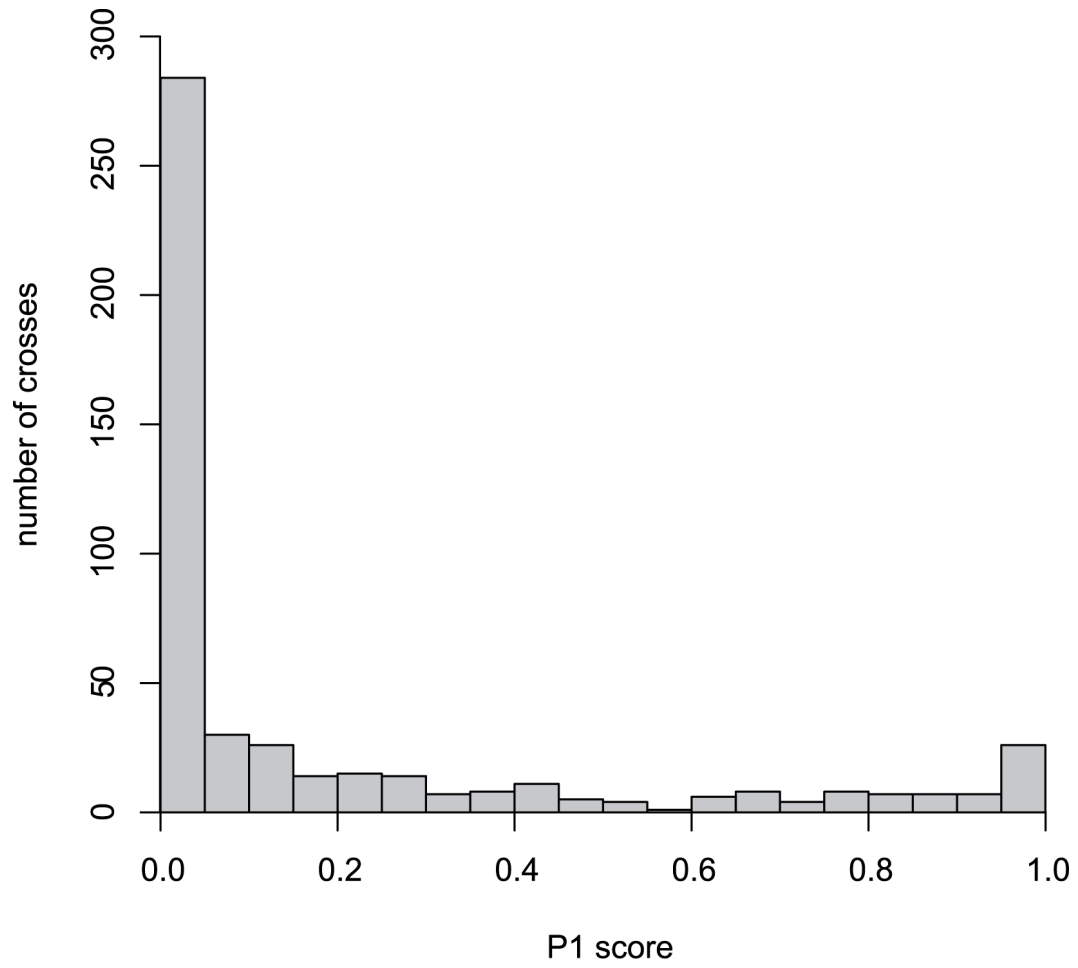


FIGURE S5.—P1 scores. P1 scores of all crosses.

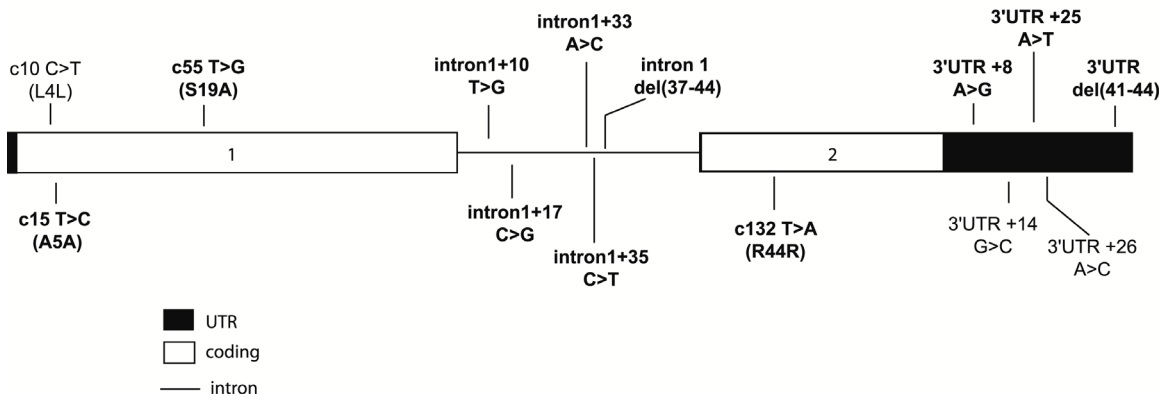
Sex Peptide polymorphisms

FIGURE S6.—*SP* polymorphisms. Location of each *SP* polymorphism identified in the chromosome 3 extraction lines (Table S1). Bold text indicates polymorphisms segregating in the ten chromosome 3 extraction lines used in this study.

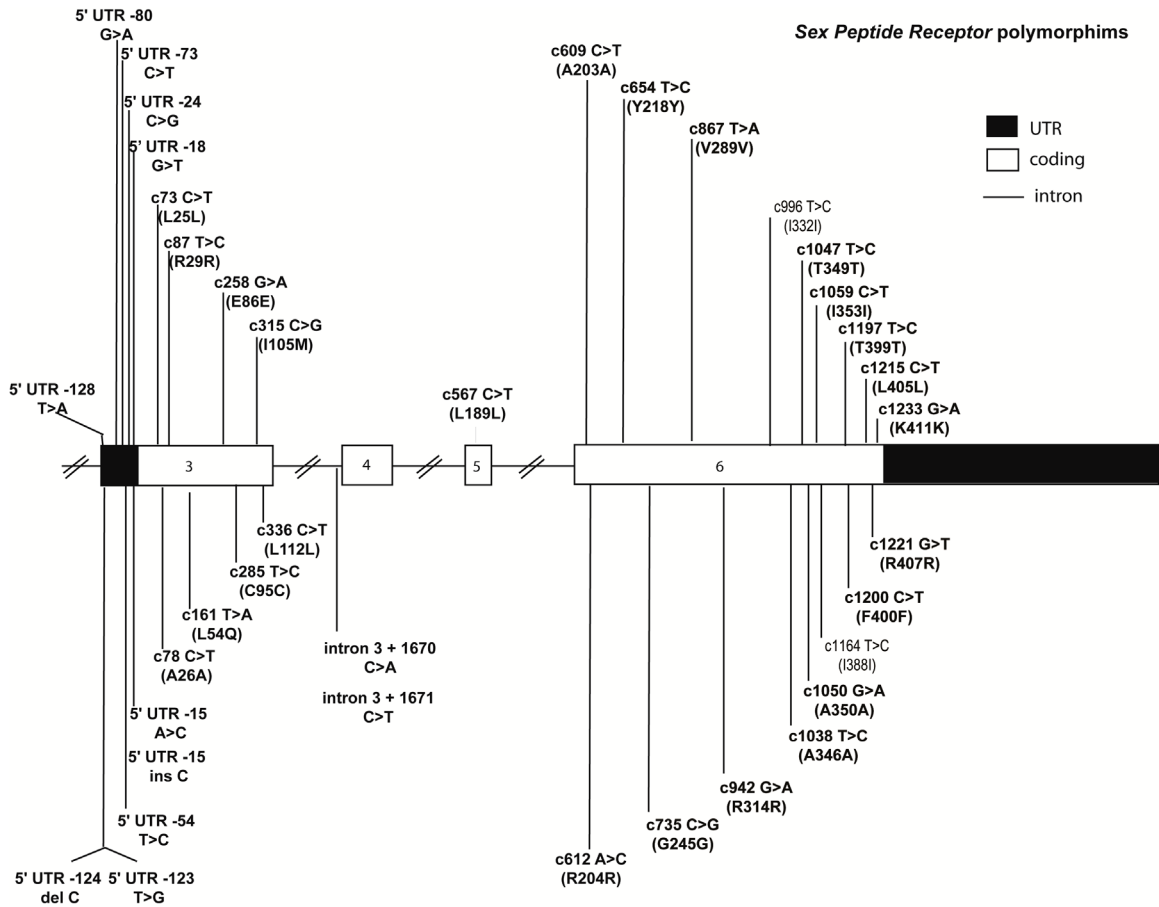


FIGURE S7.—*SPR* polymorphisms. Location of each *SPR* polymorphism identified in the chromosome X extraction lines (Table S1). Bold text indicates polymorphisms segregating in the ten chromosome X extraction lines used in this study.

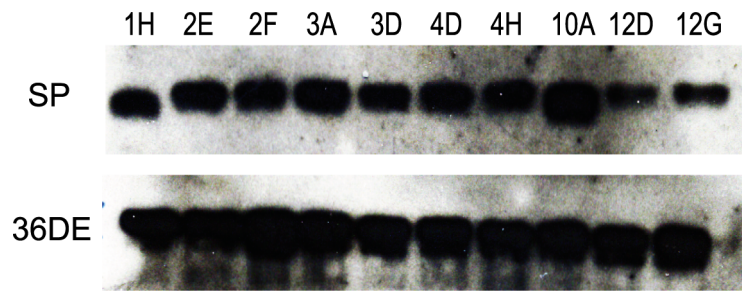


FIGURE S8.—Western analysis of SP protein levels. Males from each chromosome 3 extraction line were evaluated for SP protein levels. Acp36DE is a loading control.

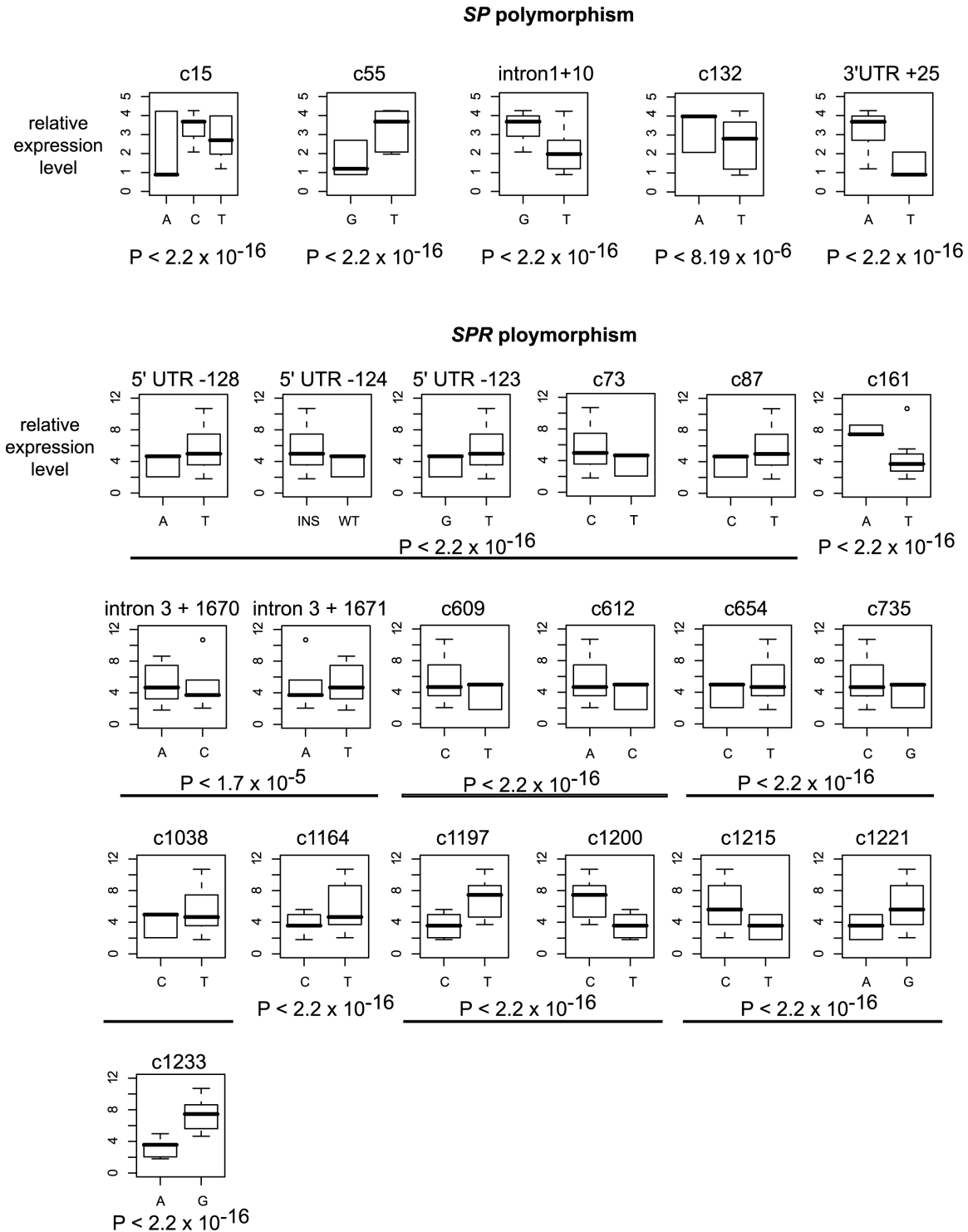


FIGURE S9.—Polymorphisms in *SP* and *SPR* drive expression levels. Polymorphisms that have an effect on *SP* and *SPR* expression are shown. Solid black lines indicate the *SPR* polymorphisms that are in linkage disequilibrium. Significance was tested by ANOVA.

TABLE S1***SP* polymorphisms**

	major allele	minor allele 1	minor allele 2
c10 (L4L)	87 C	3 T	--
c15 (A5A)	70 T	17 C	3 A
c55 (S19A)	51 T	39 G	--
intron1+10	61 T	29 G	--
intron1+17	85 C	5 G	--
intron1+33	81 A	9 C	--
intron1+35	85 C	5 T	--
intron 1 del(37-44)	86 wt	1 del	--
c132 (R44R)	86 T	4 A	--
3'UTR +8	87 A	3 G	--
3'UTR +14	86 G	4 C	--
3'UTR +25	88 A	2 T	--
3'UTR +26	87 A	3 C	--
3'UTR del(41-44)	88 wt	2 del	--

TABLE S2
***SPR* polymorphisms**

	major allele	minor allele 1	minor allele 2
5' UTR -128	43 T	8 A	--
5' UTR -124 del C	44 wt	7 del	--
5' UTR -123	43 T	7 G	1 del T
5' UTR -80	49 G	2 A	--
5' UTR -73	49 C	2 T	--
5' UTR -54	49 T	2 C	--
5' UTR -24	42 C	9 G	--
5' UTR -18	49 G	2 T	--
5' UTR -15 ins C	49 wt	2 ins C	--
5'utr -15	49 A	2 C	--
c73 (L25L)	49 C	2 T	--
c78 (A26A)	50 C	1 T	--
c87 (R29R)	46 T	5 C	--
c161 (L54Q)	47 T	4 A	--
c258 (E86E)	50 G	1 A	--
c285 (C95C)	50 T	1 C	--
c315 (I105M)	50 C	1 G	--
c336 (L112L)	49 C	2 T	--
intron 3 + 1670	31 C	20 A	--
intron 3 + 1671	31 C	20 T	--
c567 (L189L)	41 C	10 T	--
c609 (A203A)	46 C	5 T	--
c612 (R204R)	47 A	4 C	--
c654 (Y218Y)	48 T	3 C	--
c735 (G245G)	49 C	2 G	--
c867 (V289V)	46 T	5 A	--
c942 (R314R)	50 G	1 A	--
c996 (I332I)	50 T	1 C	--
c1038 (A346A)	44 T	7 C	--
c1047 (T349T)	49 T	2 C	--
c1050 (A350A)	49 G	2 A	--
c1059 (I353I)	48 C	3 T	--
c1164 (I388I)	38 T	13 C	--
c1197 (T399T)	34 T	17 C	--
c1200 (F400F)	34 C	17 T	--
c1215 (L405L)	37 C	14 T	--
c1221 (R407R)	37 G	14 T	--
c1233 (K411K)	26 G	25 A	--

TABLE S3***SP* polymorphisms**

Chr3 line	c15 (A5A)	c55 (S19A)	intron1+ 10	intron1+ 17	intron1+ 33	intron1+ 35	intron 1 del(37-44)	c132 (R44R)	3'UTR +8	3'UTR +25	3'UTR +26	3'UTR del(41-44)
1H	A	T	T	C	A	C	del	T	A	A	A	wt
2E	T	T	T	C	A	C	wt	T	A	A	A	wt
2F	C	T	G	C	A	C	wt	T	A	A	A	wt
3A	C	T	G	G	C	T	wt	T	A	A	A	wt
3D	T	A	T	C	A	C	wt	T	A	A	A	wt
4D	C	T	G	C	A	C	wt	A	A	T	A	wt
4H	A	A	T	C	A	C	wt	T	A	T	A	wt
10A	C	T	G	C	A	C	wt	T	G	A	C	wt
12D	T	T	G	C	A	C	wt	A	A	A	A	del
12G	T	A	T	C	A	C	wt	T	A	A	A	wt

TABLE S4**SPR polymorphisms**

ChrX line	5' UTR -128	5' UTR -124 del C	5' UTR - 123	5' UTR - 80	5' UTR - 73	5' UTR -54	5' UTR -24	5' UTR -18
X10	A	del	G	G	C	T	C	G
X26	T	wt	T	A	T	C	C	T
X33	T	wt	T	G	C	T	C	G
X37	T	wt	T	G	C	T	C	G
X79	A	del	G	G	C	T	G	G
X87	T	wt	T	G	C	T	C	G
X88	T	wt	T	G	C	T	C	G
X97	T	wt	T	G	C	T	C	G
X117	T	wt	T	G	C	T	C	G
X168	T	wt	T	G	C	T	C	G

ChrX line	5' UTR -15 ins C	5' UTR -15	c73 (L25L)	c78 (A26A)	c87 (R29R)	c161 (L54Q)	c258 (E86E)	c285 (C95C)
X10	wt	A	T	C	C	T	G	T
X26	ins	C	C	C	T	T	A	C
X33	wt	A	C	C	T	T	G	T
X37	wt	A	C	C	T	T	G	T
X79	wt	A	T	T	C	T	G	T
X87	wt	A	C	C	T	A	G	T
X88	wt	A	C	C	T	A	G	T
X97	wt	A	C	C	T	T	G	T
X117	wt	A	C	C	T	T	G	T
X168	wt	A	C	C	T	T	G	T

ChrX line	c315 (I105M)	c336 (L112L)	intron 3 + 1670	intron 3 + 1671	c567 (L189L)	c609 (A203A)	c612 (R204R)	c654 (Y218Y)
X10	G	C	C	A	C	C	A	C
X26	C	C	C	A	C	C	A	T
X33	C	C	C	A	C	T	C	C
X37	C	C	A	T	C	T	C	T
X79	C	C	A	T	T	C	A	T
X87	C	C	A	T	C	C	A	T
X88	C	C	A	T	C	C	A	T
X97	C	C	C	A	C	C	A	T
X117	C	T	C	A	T	C	A	T
X168	C	C	C	A	C	C	A	T

ChrX line	c735 (G245G)	c867 (V289V)	c942 (R314R)	c1038 (A346A)	c1047 (T349T)	c1050 (A350A)	c1059 (I353I)	c1164 (I388I)
X10	G	T	A	C	C	A	C	T
X26	C	T	G	T	T	G	C	T
X33	G	A	G	C	T	G	T	C
X37	C	T	G	T	T	G	C	C
X79	C	T	G	T	T	G	C	T
X87	C	T	G	T	T	G	C	T
X88	C	T	G	T	T	G	C	T
X97	C	T	G	T	T	G	C	C
X117	C	T	G	T	T	G	C	C
X168	C	T	G	T	T	G	C	T

ChrX line	c1197 (T399T)	c1200 (F400F)	c1215 (L405L)	c1221 (R407R)	c1233 (K411K)
X10	C	T	C	G	A
X26	T	C	C	G	G
X33	C	T	T	A	A
X37	C	T	T	A	A
X79	T	C	C	G	G
X87	T	C	C	G	G
X88	T	C	C	G	G
X97	C	T	T	A	A
X117	C	T	C	G	G
X168	T	C	C	G	A

TABLE S5***SP* SNP effects of measured phenotypes**

	egg total	progeny total	hatchability	remating	P1
c15 (A5A)	4.52×10^{-4}	1.50×10^{-11}	1.68×10^{-25}	3.34×10^{-8}	8.59×10^{-8}
c5 (S19A)	1.10×10^{-3}	1.51×10^{-6}	9.94×10^{-8}	9.65×10^{-8}	7.90×10^{-9}
intron1+10	6.57×10^{-3}	2.00×10^{-9}	1.85×10^{-24}	2.75×10^{-7}	4.72×10^{-12}
intron1+17	NS	2.91×10^{-2}	4.34×10^{-5}	2.68×10^{-5}	2.30×10^{-4}
intron1+33	NS	2.91×10^{-2}	4.34×10^{-5}	2.68×10^{-5}	2.30×10^{-4}
intron1+35	NS	2.91×10^{-2}	4.34×10^{-5}	2.68×10^{-5}	2.30×10^{-4}
intron 1 del(37-44)	NS	5.99×10^{-3}	1.46×10^{-7}	NS	NS
c132 (R44R)	1.53×10^{-3}	1.74×10^{-5}	2.53×10^{-5}	1.09×10^{-4}	NS
3'UTR +8	2.25×10^{-9}	3.51×10^{-19}	1.15×10^{-29}	2.20×10^{-16}	4.33×10^{-16}
3'UTR +25	NS	4.11×10^{-5}	6.96×10^{-10}	6.86×10^{-4}	NS
3'UTR +26	2.25×10^{-9}	3.51×10^{-19}	1.15×10^{-29}	2.20×10^{-16}	4.33×10^{-16}
3'UTR del(41-44)	NS	NS	NS	NS	3.18×10^{-16}

NS - Not significant below $P \leq 0.05$

TABLE S6***SPR* SNP effects of measured phenotypes**

	egg total	progeny total	hatchability	remating	P1
5' UTR -128	NS	NS	NS	1.21 x 10 ⁻²	NS
5' UTR -124 del C	NS	NS	NS	1.21 x 10 ⁻²	NS
5' UTR -123	NS	NS	NS	1.21 x 10 ⁻²	NS
5' UTR -80	5.63 x 10 ⁻²¹	8.02 x 10 ⁻¹⁹	8.13 x 10 ⁻⁴	2.80 x 10 ⁻³	NS
5' UTR -73	5.63 x 10 ⁻²¹	8.02 x 10 ⁻¹⁹	8.13 x 10 ⁻⁴	2.80 x 10 ⁻³	NS
5' UTR -54	5.63 x 10 ⁻²¹	8.02 x 10 ⁻¹⁹	8.13 x 10 ⁻⁴	2.80 x 10 ⁻³	NS
5' UTR -24	7.21 x 10 ⁻⁴	2.95 x 10 ⁻³	NS	4.78 x 10 ⁻⁶	NS
5' UTR -18	5.63 x 10 ⁻²¹	8.02 x 10 ⁻¹⁹	8.13 x 10 ⁻⁴	2.80 x 10 ⁻³	NS
5' UTR -15 ins C	5.63 x 10 ⁻²¹	8.02 x 10 ⁻¹⁹	8.13 x 10 ⁻⁴	2.80 x 10 ⁻³	NS
5' UTR -15	5.63 x 10 ⁻²¹	8.02 x 10 ⁻¹⁹	8.13 x 10 ⁻⁴	2.80 x 10 ⁻³	NS
c73 (L25L)	NS	NS	NS	1.21 x 10 ⁻²	NS
c78 (A26A)	7.21 x 10 ⁻⁴	2.95 x 10 ⁻³	NS	4.78 x 10 ⁻⁶	NS
c87 (R29R)	NS	NS	NS	1.21 x 10 ⁻²	NS
c161 (L54Q)	5.56 x 10 ⁻⁵	3.07 x 10 ⁻⁴	NS	NS	NS
c258 (E86E)	5.63 x 10 ⁻²¹	8.02 x 10 ⁻¹⁹	8.13 x 10 ⁻⁴	2.80 x 10 ⁻³	NS
c285 (C95C)	5.63 x 10 ⁻²¹	8.02 x 10 ⁻¹⁹	8.13 x 10 ⁻⁴	2.80 x 10 ⁻³	NS
c315 (I105M)	3.30 x 10 ⁻³	NS	2.73 x 10 ⁻³	NS	NS
c336 (L112L)	4.88 x 10 ⁻²	4.38 x 10 ⁻³	2.44 x 10 ⁻³	6.65 x 10 ⁻³	NS
intron 3 + 1670	2.06 x 10 ⁻⁴	3.48 x 10 ⁻³	NS	8.97 x 10 ⁻⁵	4.36 x 10 ⁻²
intron 3 + 1671	2.06 x 10 ⁻⁴	3.48 x 10 ⁻³	NS	8.97 x 10 ⁻⁵	4.36 x 10 ⁻²
c567 (L189L)	NS	NS	8.65 x 10 ⁻³	3.42 x 10 ⁻⁸	NS
c609 (A203A)	NS	NS	NS	NS	NS
c612 (R204R)	NS	NS	NS	NS	NS
c654 (Y218Y)	NS	NS	1.21 x 10 ⁻⁴	3.80 x 10 ⁻⁴	NS
c735 (G245G)	NS	NS	1.21 x 10 ⁻⁴	3.80 x 10 ⁻⁴	NS
c867 (V289V)	NS	NS	3.40 x 10 ⁻²	4.24 x 10 ⁻⁴	NS
c942 (R314R)	3.30 x 10 ⁻³	NS	2.73 x 10 ⁻³	NS	NS
c1038 (A346A)	NS	NS	1.21 x 10 ⁻⁴	3.80 x 10 ⁻⁴	NS
c1047 (T349T)	3.30 x 10 ⁻³	NS	2.73 x 10 ⁻³	NS	NS
c1050 (A350A)	3.30 x 10 ⁻³	NS	2.73 x 10 ⁻³	NS	NS
c1059 (I353I)	NS	NS	3.40 x 10 ⁻²	4.24 x 10 ⁻⁴	NS
c1164 (I388I)	NS	NS	4.09 x 10 ⁻²	1.76 x 10 ⁻²	4.45 x 10 ⁻²
c1197 (T399T)	8.76 x 10 ⁻³	NS	NS	NS	5.34 x 10 ⁻³
c1200 (F400F)	8.76 x 10 ⁻³	NS	NS	NS	5.34 x 10 ⁻³
c1215 (L405L)	NS	NS	NS	NS	NS
c1221 (R407R)	NS	NS	NS	NS	NS
c1233 (K411K)	3.34 x 10 ⁻²¹	1.27 x 10 ⁻¹⁵	NS	4.59 x 10 ⁻⁹	1.30 x 10 ⁻²

NS - Not significant below $P \leq 0.05$